

Hydraulic Breaker Owner's Manual



Rock Breakers, Inc.
www.rbibreakers.com

Contents

Safety precautions	1
Safety precautions	1
Sticker list & Placed on the Breaker.....	3
Product	4
Standard Specification(Silence Type).....	4
Standard Specification(Top Type)	6
General Information	8
How the Tool Breakers Rock.....	8
Sizing the Hydraulic Breaker.....	9
Based on Carrier Weight.....	10
Based on the Type of Work	11
Recommended Hydraulic Oils	12
Oil is Too thick or Too Thin	12
Hydraulic Oil Purity	12
Hydraulic Oil Cooling	13
Safety Rules	14
General Safety Precautions.....	15
Practice Safe Maintenance.....	15
Precautions for Working on Hydraulic Systems	16
Precautions for Handling Hydraulic Oil	17
Work Site Precautions.....	17
Fire Prevention	17
Welding and Grinding Work.....	18
Work on Painted Surfaces	18
Rubber and Plastics.....	19
Hazard Alerts	20
Transporting Safety Precautions	22
Installation	23
General	23
Mounting the Breaker	24
Setting Flow and Pressure	24
Setting the Flow.....	24
Setting the Relief Pressure.....	24
Start-Up	24
Typical Hydraulic Circuit	24
Carrier with Auxiliary Hydraulic Circuit.....	25
Typical hydraulic Circuits	26
Carrier without Auxiliary Hydraulic Circuit.....	26
Operation	27
Suggestions for Efficient Operation	27
End of Shift.....	28
Improper Use of Breaker	28
Blank Firing	29
Breaking Oversize Material	30

RBI HYDRAULIC BREAKER USER MANUAL

Trenching and Excavation	30
Breaking Concrete	30
Breaking on a Grizzly	31
Guide to Tool Choice	31
Underwater Operation	32
Installing the Air Supply Kit	32
Air flow rate for underwater operation	32
Illustration for Installing the Underwater Breaker	33
High/Low Speed Selector Valve	34
Maintenance	35
Greasing the Breaker	35
Automatic Greasing Systems	35
Comparison of Automatic Lubrication Systems to Manual Lubrication	36
Seal & O-Ring	36
Wear Tolerance	37
Changing the Breaker Tool	39
Tool and Front Tool Bushing Clearance	39
Tool Removal	39
Tool Installation	40
Cushion Chamber Gas Pressure – Checking	41
Cushion Chamber(Back Head) Gas Pressure-Checking	41
Back Head (Cushion Chamber) Gas Pressure	42
Adjusting Increasing the Pressure	42
Torque and Gas Pressure Table	43
Nitrogen Charging Pressure vs Ambient temperature	44
Accumulator Gas Pressure – Checking	44
Accumulator Gas Pressure	45
Nitrogen Charging Pressure vs Ambient Temperature	46
Maintenance Schedule	47
Breaker Disassembly	49
Removing Breaker Body from Housing	50
Wear Pads	50
Weight of Main body	51
Breaker Body Disassembly	51
Rear Head Removal	52
Accumulator Removal	52
Diaphragm Replacement	53
Accumulator Assembly	53
Charging the Accumulator	54
Control Valve Removal and Disassembly	54
Control Valve Inspection	54
Piston Removal	55
Cylinder Removal	56
Cylinder Inspection	56
Cylinder clean-up	57
Seal Bushing Inspection	58
Tie Rod(through Bolt) Installation	58

RBI HYDRAULIC BREAKER USER MANUAL

Cylinder Installation.....	58
Seal Bushing – Re-sealing	59
Piston Installation.....	59
Control Valve Installation.....	60
Installing Rear(Back) Head	60
Tie Rod(through Bolt) nut torque.....	60
Charging the Cushion Chamber	61
Breaker Assembly.....	61
Top Mount Bracket Bolt torque.....	62
Start-up.....	63
High Speed and Low Speed Valve Adjusting.....	63
High Speed Stroke Setting,.....	63
Low Speed Stroke Setting,.....	63
Troubleshooting Guide.....	64
Oil Leakage.....	64
Hydraulic Breaker.....	65
Does not hammer	65
Does not Impact	65
Lack of Power.....	65
Erratic hammering.....	66
Tool Mushrooming	66
Rapid Increase in Oil temperature	66
Emulsification of Oil	66
Leakage	67
Gas Leakage.....	67
Erratic Blows After Breaker has been Operating normally.....	68
Blows/min decreased.....	68
Tool Breaking	68
Breaker Tool.....	69
Normal Breaker tool Wear.....	69
Breaker tool Fatigue Failures.....	69
Cause and Effect of Fatigue.....	70
Other Causes of Increased Tool Fatigue Stress.....	70
Area of typical tool Failures.....	71
Guide to Warranty Claims	71
Mushrooming	72
Steel Defect Failure	72
Removal and Storage.....	73
Short-term Storage	73
Long-term Storage.....	73
Breaker Stored Lying Down.....	73
Breaker Stored Standing Up.....	73
Initial Start-up after Storage	74
Endosures.....	75
HYDRAULIC BREAKER INSTALLATION CARD	75
WARRANTY CLAIM FORM	76
WARRANTY PERIOD OF SUPPLIER	77

1. Safety precautions

1.1 Safety precautions

This manual contains safety, operation, and routine maintenance instructions. It doesn't contain the service for assembling and disassembling instruction.

Please read the following warning.



Serious injury or death could result from the improper repair or service of this breaker. Repairs or service to this breaker must only be done by an authorized and certified dealer.

Most of the accidents are caused by disregarding the basic rules of operation inspection or repair, or by neglecting the inspection before operation. Many accidents can often be avoided by recognizing potentially hazardous situations before an accident occurs. Before operating, inspecting or repairing this machine, be sure to read and fully understand the preventive methods and warnings described on the machine or in this manual. If not, never operate, inspect or repair this machine

Safety labels and messages are classified as follows so that the users can understand the warnings on the machine or in this manual.



Indicates and imminently hazardous situation which, if not avoided, will result in death or serious injury. This signal wors is to be limited to the most extreme situations.



Indicates a potentially hazardous situation which, if not avoided, could result in death or serious injury.



Indicates a potentially hazardous situation which, if not avoided, may result in minor or moderate injury, It may also be used to alert against unsafe practices.



Signs used to indicate a statement of company policy directly or indirectly related to the safety of personal or protection of property.

The safety messages including the preventive measures to avoid danger.

For safety, common items are described in "SAFETY PRECAUTIONS" , and others are mentioned in the succeeding pages.

Supplier cannot anticipate every possible circumstance that might involve a potential hazard on operation, inspection or repair. Therefore the warnings in this manual are not all inclusive. If an operation, inspection or repair not described in this manual is used, you must take measures for safety by yourself.



Observe the cautions and take a preventive measure for safety

The Hydraulic Breaker will provide safe and dependable service if operated in accordance with the instructions given in this manual. Read and understand this manual, any decals and tags attached to the breaker before operation. Failure to do so could result in personal injury or equipment damage.

- Operate the breaker in accordance with all laws and regulations which affect you, your equipment, and the worksite.
- Do not operate the breaker until you have read this manual and thoroughly understood all safety, operation and maintenance instructions.
- Do not operate the breaker until you have read the carrier equipment manual and thoroughly understood backhoe or excavator or similar equipment used to operate the breaker. The word "carrier" as used in this manual, means a backhoe or excavator or similar equipment used to operate the breaker.
- Ensure that all maintenance procedures recommended in this manual are completed before using the equipment.
- The operator must not operate the breaker or carrier if any people are within the area where they may be injured by flying debris or movement of the equipment.
- Know the limits of your equipment.
- Before starting a work, check the prohibitions, cautions and working processes in a working site with the field overseer, Observe all of them strictly.
- Wear such protective tools as a helmet, safety shoes, etc. to perform a work.
Make use of the protective glasses, earplugs, gloves and other protective tools if necessary.
- Establish a training program for all operators to ensure safe operation. Do not operate the breaker unless thoroughly trained or under the supervision of an instructor.
Become familiar with the carrier controls before operating carrier and breaker. While learning operate the breaker and carrier, do so at a slow pace. If necessary, set the carrier to the slow position.
- Make sure all controls (levers and pedals) are in the neutral position before starting the carrier.
- Before leaving the carrier, always lower the boom and insure the carrier is stable.
Never leave the machine with the engine running. Always engage the parking brake.
- Stop the engine before attempting to make any repairs, adjustments or servicing to either the carrier or the breaker.
- Do not operate the breaker at oil temperature above 175 °F/80°C. Operation at higher temperature can damage the internal components of the breaker and carrier and will result in reduced breaker performance.
- Do not operate a damaged, leaking, improperly adjusted, or incompletely assembled breaker.
- Do not modify this breaker in any manner.
- Use only breaker parts manufactured by Supplier. Usage of breaker rod produced by another manufacturer may damage the breaker and will void the warranty.
- To avoid personal injury or equipment damage, all breaker repair, maintenance and service must only be performed by authorized and properly trained personnel.
- If you do not understand how to operate safely your breaker, contact an authorized dealer for assistance.

- Keep this manual with the breaker.
- Do not operate this equipment if you are taking medication which may affect your mental judgement or physical performance.
- Do not operate this equipment if you are under the influence of drug or alcohol.
- Remove breaker form carrier during transportation.

1.2 Sticker list & Placed on the Breaker

Warning sticker

- 1) Use hearing protection
- 2) Use eye protection
- 3) Use breathing protection
- 4) Use the manual before use

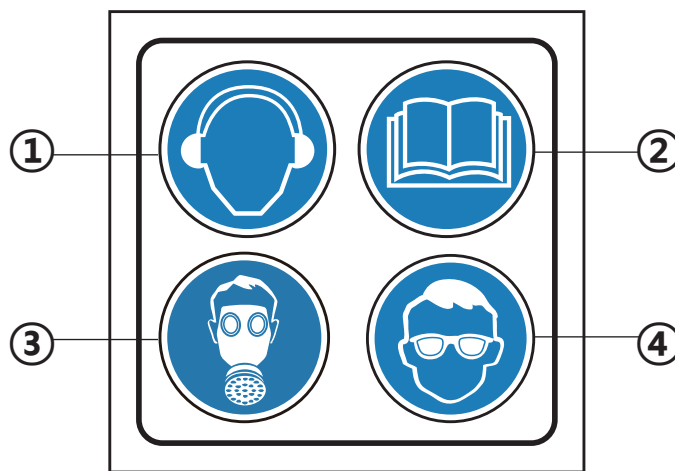

Warning Sticker

GREASING



1. Fill cavity with recommended grease.
2. Grease whenever pin looks dry.
3. Failure to comply with these instructions can result in damaged to demolition & sorting grab and will void the warranty.

Product

Standard Specification (Silence Type)

Contents / Model	RB105S	RB125S	RB155S	RB305S	RB505S
Weight (kg)	102	126	152	224	295
Length (mm)	1,210	1,308	1,401	1,428	1,643
Required Oil Flow (L/M)	15~25	20~30	25~50	30~60	40~70
Operate Pressure (bar)	90~120	90~120	90~120	100~130	110~140
Impact Rate (bpm)	800~1,400	700~1,200	600~1,100	500~1,000	500~900

Contents / Model	RB755S	RB1005S	RB1500S	RB2000S	RB3600S
Weight (kg)	375	571	861	1,296	1,500
Length (mm)	1,730	2,146	2,296	2,628	2,683
Required Oil Flow (L/M)	50~90	60~100	80~110	90~120	100~150
Operate Pressure (bar)	120~150	130~160	150~170	150~170	160~180
Impact Rate (bpm)	400~800	400~800	350~700	350~650	350~600

Contents / Model	RB4000S	RB4500S	RB5800S	RB8000S	RB9500S
Weight (kg)	1,825	2,071	2,635	2,850	3,990
Length (mm)	2,802	3,130	3,274	3,354	3,758
Required Oil Flow (L/M)	120~180	150~210	180~240	200~260	210~290
Operate Pressure (bar)	160~180	160~180	160~180	160~180	160~180
Impact Rate (bpm)	350~500	300~450	300~450	250~400	200~350

EXTERNAL DIMENSION (Silence Type)

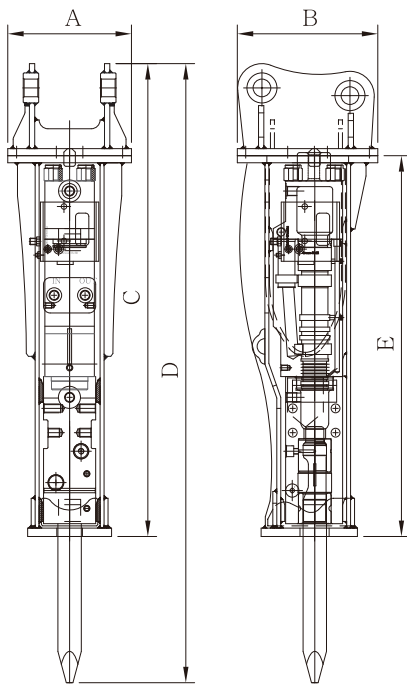

	RB105S	RB125S	RB155S	RB305S	RB505S
A	260	260	280	350	350
B	294	292	318	380	412
C	942	1,011	1,070	1,104	1,268
D	1,210	1,308	1,401	1,428	1,643
E	725	790	862	881	992

	JRB755S	RB1005S	RB1500S	RB2000S	RB3600S
A	328	440	440	500	560
B	476	574	574	689	730
C	1,311	1,599	1,736	1,997	2,020
D	1,730	2,146	2,296	2,628	2,683
E	1,043	1,296	1,433	1,579	1,660

	RB4000S	RB4500S	RB5800S	RB8000S	RB9500S
A	600	640	640	640	670
B	743	829	829	838	972
C	2,075	2,312	2,411	2,485	2,888
D	2,802	3,130	3,274	3,354	3,758
E	1,715	1,852	1,951	2,025	2,333

Product

Standard Specification (Top Type)

Contents / Model	RB105	RB125	RB155	RB305	RB505
Weight (kg)	72	92	150	250	275
Length (mm)	1,227	1,281	1,342	1,472	1,600
Required Oil Flow (L/M)	15~25	20~30	25~50	30~60	40~70
Operate Pressure (bar)	90~120	90~120	90~120	100~130	110~140
Impact Rate (bpm)	800~1,400	700~1,200	600~1,100	500~1,000	500~900

Contents / Model	RB755	RB1005	RB1500	RB2000	RB3600
Weight (kg)	295	500	795	1,250	1,450
Length (mm)	1,790	2,101	2,326	2,604	2,691
Required Oil Flow (L/M)	50~90	60~100	80~110	90~120	100~150
Operate Pressure (bar)	120~150	130~160	150~170	150~170	160~180
Impact Rate (bpm)	400~800	400~800	350~700	350~650	350~600

Contents / Model	RB4000	RB4500	RB5800	RB8000	RB9500
Weight (kg)	1,780	2,100	2,700	2,995	4,100
Length (mm)	2,828	3,055	3,255	3,395	3,709
Required Oil Flow (L/M)	120~180	150~210	180~240	200~260	210~290
Operate Pressure (bar)	160~180	160~180	160~180	160~180	160~180
Impact Rate (bpm)	350~500	300~450	300~450	250~400	200~350

EXTERNAL DIMENSION (Top Type)

	RB105	RB125	RB155	RB305	RB505
A	260	260	280	350	350
B	294	292	218	380	407
C	942	1,011	954	943	1,043
D	1,210	1,308	1,434	1,448	1,670
E	725	790	746	723	765

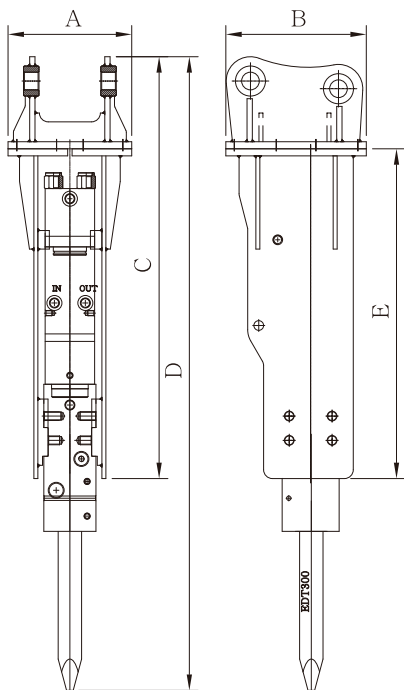

	RB755	RB1005	RB1500	RB2000	RB3600
A	390	438	450	500	560
B	443	568	574	689	715
C	1,153	1,473	1,521	2,016	2,008
D	1,790	2,226	2,301	2,653	2,710
E	851	1,134	1,218	1,601	1,648

	RB4000	RB4500	RB5800	RB8000	RB9500
A	600	600	620	760	760
B	763	802	802	849	928
C	2,108	2,292	2,393	2,450	2,940
D	2,842	3,145	3,278	3,323	3,837
E	1,748	1,832	1,933	1,985	2,385

General Information

How the Tool Breakers Rock

The following paragraphs describe what happens to break rock when the piston strikes the tool.

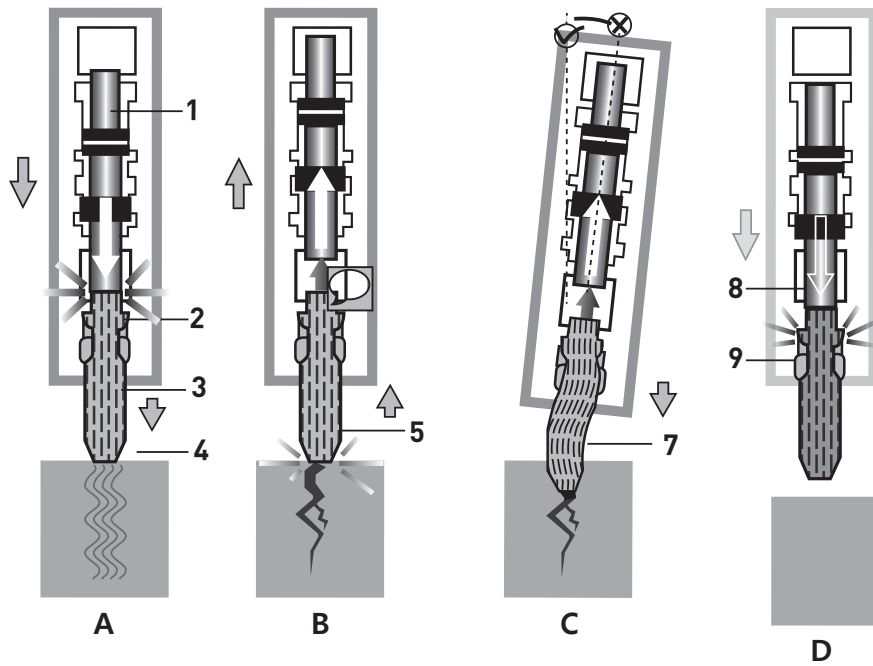

(A) Contact-Initial Compression Stress Wave

When the piston (1) strikes the top of the tool (2), it sends a compressive stress wave (3) down to the working end of the tool. If the tool is touching a rock, this energy/force (compressive stress wave) travels out the tool directly into the rock (4), fracturing it.

(B) Recoil-Reflected Stress Wave

Immediately following the initial compressive stress wave, a reflected stress wave is formed (5), which travels back up the tool, 'bouncing' the piston up off the top of the tool.

This cycle of compressive and tensile stresses flowing up and down the tool is repeated with each piston blow (E&F).

(C) Bending

Anything interfering with the strength of the compressive stress waves (7) during operation such as blank-firing (free-running) or prying with the tool, can lower breaker performance and cause tool fatigue. The breaker must be at a 90° angle to the face of the rock.

(D) Blank-firing

Blank-firing the breaker without the tool pressing on a rock causes the energy that normally travels out the tool into the rock (8), to impact the retainer pins (9) and front head causing excess stress to these components.

Sizing the Hydraulic Breaker

When sizing the breaker to the machine, two key points should be given careful consideration:

- Machine operating weight
- Hydraulic system capabilities

With the correct carrier weight, Supplier offers hydraulic breakers that are designed to break any material that the machine can handle. Sizing the breaker by carrier hydraulics gives the operator a carrier/breaker combination designed to optimize the system efficiency, thereby reducing heat generation and eliminating power loss. The following steps will result in a well-matched installation. This manual will not cover all types of applications, so for assistance in any unusual situations please contact your Supplier representative.

Based on Carrier Weight

By using the Carrier Sizing Chart below, you can narrow your hammer choice. Normally breaker production rate is the most crucial factor when trying to choose a breaker size. It is of great benefit to do some research and understand your hydraulic system capabilities and the material size and hardness before determining an expected production rate. This rate will also be affected by breaking conditions and the operator.



BREAKER MODEL	Carrier Weight in Metric Ton						
	0	5	10	15	20	25	30
RB105 150 ft•ib (203j)			0.8~2.5				
RB125 214 ft•ib (290j)			1.2~3				
RB155 236 ft•ib (320j)			2.5~4.5				
RB305 406 ft•ib (550j)			3~5.5				
RB505 509 ft•ib (690j)			4~7				
RB755 664 ft•ib (900j)			6~9				
RB1005 959 ft•ib (1,300j)			7~14				
RB1500 1,549 ft•ib (2,100j)			11~16				
RB2000 2,139 ft•ib (2,900j)					15~18		
RB3600 2,622 ft•ib (3,555j)					18~21		
RB4000 3,098 ft•ib (4,200j)					18~26		

RBI HYDRAULIC BREAKER USER MANUAL



BREAKER MODEL	Carrier Weight in Metric Ton									
	25	30	35	40	45	50	55			
RB4500 3,836 ft•ib (5,200j)	25.0-30.0									
RB5800 4,794 ft•ib (6,500j)		28.0-35.0								
RB8000 6,638 ft•ib (9,000j)			30.0-40.0							
RB9500 8,851 ft•ib (12,000j)					40.0-55.0					

Based on the Type of Work

The Production Rate is the next important factor to consider in sizing the breaker. Most situations call for the largest breaker that your carrier could handle. The largest breaker is therefore the one to choose.

The lifting capacity of your machine is then the limiting factor. The carrier machine must be able to safely handle the breaker at any distance out from the machine where you might be working.

Small Breakers

Smaller sized breakers up to 1,000 ft-lb class (1350 joule) are typically used in concrete and other light duty work.

Medium Breakers

Medium sized breakers 1,500-4,000 ft-lb class (2000-5400 joule) are used in both concrete and rock applications with limitations on the size and amount of material to be broken.

Large Breakers

Larger breakers greater than the 4,000 ft-lb class (5400 joule) are typically used in hard rock, high production applications.

Breaking Oversize

When breaking oversize material, the breaker is expected to break the material down quickly into multiple pieces.

This is optimum production. If the operator has to re-position the breaker towards the edge of the rock and gradually downsize the material, the production rate slows down.

To assess which breaker will effectively handle this application, the size and handness of the material must be known.

For example, if a 4 cubic yard piece of hard rock (20,000 psi or greater) needs to be broken in half, a 7,500 ft-lb or larger breaker is required.

If a 2 cubic yard piece of limestone (20,000 psi or less) needs to be broken in half, a 3,000-5,000 ft-lb breaker is required.

Trenching

When trenching, the breaker is expected to fracture a solid mass of rock into manageable pieces.

The size of the material could be hundreds of cubic yards, and the energy will be quickly absorbed.

This is why it is recommended to work from a bench so the rock has somewhere to break out.

When trenching in limestone or medium hard rock, use a 3,000 -5,000 ft-lb breaker.

When working in hard material use a 7,500 -10,000 ft-lb breaker.

When working in hard material use a 7,500-10,000 ft-lb breaker, and if high production is critical, a 13,500 ft-lb breaker would be beneficial.

Breaking Concrete

When breaking Concrete, the breaker is expected to penetrate the material, allowing it to crack and shake loose from the reinforcing steel. High frequency breakers tend to provide better performance in this application. It is not the energy per blow, but the fast blow rate that destroys the concrete's structural integrity.

On concrete walls, footings and floors use a 750-1,500 ft-lb breaker.

With larger projects consisting of large footings greater than 4 cubic yards, use a 2,000-5,000 ft-lb breaker.

The high production demand of bridge and building demolition requires a 7,500-10,000 ft-lb breaker.

Recommended Hydraulic Oils

Oil is Too Thick or Too Thin

Thick oil may cause:

- Difficult start-up
- Stiff operation
- Danger of cavitation in the pumps
- Accelerated wear of pumps and breaker
- Sticky valves
- Filter bypasses (oil impurities not removed), contamination in hydraulic tank

Thick oil may cause:

- Efficiency losses (internal leakage)
- Breaker strikes slowly and irregularly
- Damage to gaskets and seals, leaks
- Accelerated wear of parts from decreased lubrication

Hydraulic Oil Purity

It is beneficial for the tank return line to pass through a filter. This ensures dirt introduced into the system by connecting and disconnecting the breaker is caught before entering the carrier's pump. Dirt destroys a hydraulic system, so ensure the breaker hose connections are protected when the breaker is not in use.

Impurities also heat and age the hydraulic oil.

Air and water are also considered impurities in oil (not all impurities can be seen with the naked eye).

Impurities can enter the hydraulic system:

- When components are repaired or serviced
- During hydraulic oil changes and refilling
- When the breaker is operated with worn cylinder and seals
- When hoses are disconnected during breaker removal/installation

Results of damage by hydraulic oil impurity:

- Working life of pump(s) significantly shortened – rapid wear of parts, corrosion.
- Valves do not function properly – spools bind, accelerated wear of parts, blocking of small holes.
- Rapidly accelerated wear on cylinders and seals.
- Reduced breaker efficiency – accelerated wear of moving parts and seals, piston seizing up, oil leakage.
- Shortened working life and reduced efficiency of hydraulic oil – overheats, ages, electrochemical changes.
- Excessive large particle contamination can cause severe damage to the piston and piston cavity.

▲ CAUTION!

After a major component failure, the hydraulic system must be flushed.

Component damage is only a symptom. The trouble itself cannot be cured by removing the symptom.

Hydraulic Oil Cooling

▲ CAUTION!

The maximum permitted hydraulic oil temperature in continuous breaker use is 120°-158°F(50°-70°C), depending on the viscosity of the oil in the system.

It is essential the carrier has a reliable hydraulic oil temperature sensor installed. The temperature of the hydraulic oil will depend upon ambient conditions, efficiency of the cooling system, and the amount of breaker use. Additional cooling may be required.

Safety Rules

Supplier policy is to produce products that are safe and reliable. However, even when using well-engineered equipment, there will always be an element of risk. To minimize the risks and promote safety at all times, this section of the operator's manual details a number of safety rules that must always be followed and obeyed.

IMPORTANT! When it comes to safety, nothing will ever replace a careful operator.

This policy Supplier's Operation Manual is the primary source in maintaining optimum performance from the hydraulic breaker. It is imperative that the operator reads and understands all the safety information in this manual before proceeding. Failure to follow the instructions or heed the warnings could result in injury or death.

Proper care is your responsibility.

Supplier cannot anticipate every possible circumstance that might involve a hazard. The hazard alerts in this publication and on the product, are therefore not all inclusive. If a tool, procedure, work method, or operating technique not specifically recommended by Supplier is used, you must satisfy yourself that it is safe for you and others. You should also ensure the hydraulic breaker will not be damaged or made unsafe by the operation, maintenance, or repair procedures you choose.

- It is the obligation of the operator to make sure that all warning decals are in place on the machine and that they are readable.
Accidents may otherwise occur. Contact your distributor or for replacement manuals or decals.
- Should there be any information or instructions in this manual that are not in compliance with local laws and regulations in force in the country or region where this equipment is operated, the local laws and regulations must take precedence.

General Safety Precautions

▲ WARNING!

The operator of this machine must have sufficient knowledge and instructions before he/she operates the machine.

Untrained operators may cause severe injuries or even fatalities.

Therefore, it is important that you read and follow the instructions of this Supplier's Operation Manual.

- Never use a machine that has no Supplier's Operation Manual available. Learn and understand the safety signs and symbols on the machine and the operator instructions before you begin to use the machine.



- Wear protective clothing-know and use the protective equipment that is to be worn when operating or servicing the hydraulic breaker.

Hard hats, protective glasses, protective shoes, gloves, reflector type vests, respirators and ear protection are types of equipment that may be required. Prolonged exposure to loud noise can cause hearing damage .



- Operate the machine only when physically fit and not under the influence of alcohol or drugs.
- Avoid loose fitting clothing, loose or uncovered long hair, jewelry and loose personal articles. These can get caught in moving parts.
- Keep all personnel well away from the hydraulic breaker when it is operating. Small pieces of stone or concrete can fly off causing serious injury to bystanders.
- Keep a first aid kit and a multi-purpose fire extinguisher on or near the machine, and know how to use them. Know where to get help.
- Before starting up the hydraulic breaker, perform a daily inspection and include it in the daily machine walk-around. Pay special attention to hoses and electrical connections. Make repairs before operating the breaker.

Practice Safe Maintenance

- Only trained mechanics should repair or disassemble the hydraulic breaker. Be sure you understand a service procedure before beginning any work; if you are uncertain, contact your Supplier representative.
- Avoid unauthorized machine modifications – never substitute alternate parts not intended for the application. This could create hazardous situations or machine failure. Supplier Engineering must approve all machine modifications; they can affect product reliability and machine stability.
- Before performing any work on the machine, attach a DO NOT OPERATE or similar tag in the operator's tag in the operator's cab to alert others of service work being performed. Remove engine key and master key switch. Unexpected machine movement can cause serious injury.
- The cushion chamber(back head) is charged with nitrogen(N₂)-a non-explosive inert gas. Only use N₂ when refilling it. Charging it with any other gas could trigger an explosion and lead to serious or possibly fatal injuries.
- Relieve all gas pressure in the cushion chamber before beginning disassembly procedures to avoid the potential for accidents or injury. It remains under pressure even after the hydraulic system is depressurized. Refer to the Maintenance section of the manual.

- Stay clear of the tool when charging the breaker cushion chamber. Gas pressure may cause unexpected piston movement and force the tool to jump against the tool retainer pins.
- Use only lifting devices with sufficient capacity to safely support the expected weight you are lifting.
- All lifting devices (straps, slings, chains, ratchet blocks, etc.) must comply with applicable local regulations and certifications. Supplier cannot accept responsibility for the use of sub-standard equipment and work practices.
- When lifting or supporting the breaker or its parts, use equipment with a sufficient lifting capacity.
- Use the lifting eyes or lifting points that are located on certain breaker components.
- Do not work under a hanging or suspended load!
- If a jack is used, the floor or ground must be flat and of sufficient strength to support the expected load.

Precautions for Working on Hydraulic Systems

▲ WARNING!

Risk of personal injury! Wear safety glasses and use protective gloves.

Relieve all trapped pressure before performing any service to the hydraulic system.

Pressure can be maintained in the hydraulic circuits long after the power source and pump have been shut down.

- Relieve all pressure before disconnecting hoses or tubes.
- Tighten all connections before applying pressure.

It is important that each person who comes in contact with the machine be alert to any faults.

Follow these basic precautions:

- Never adjust a pressure relief valve or other pressure-limiting device to a higher pressure than specified.
- Check to make sure hydraulic hoses are not worn or damaged, and are routed to avoid chafing.
- Replace any hydraulic hose immediately that shows signs of swelling, wear, leaks or damage before it bursts.
- Hydraulic fluid escaping under pressure can penetrate the skin causing serious injury.
Do not use your hand to check for hydraulic oil leaks. Use a piece of cardboard.
If skin penetration occurs, seek medical attention immediately.
Relieve all pressure before disconnecting hoses.
- Do not bend or strike high-pressure lines, tubes or hoses, or reinstall them in a bent or damaged condition.

Precautions for Handling Hydraulic Oil

▲ WARNING!

Risk of burns! Use protective work gloves.

- Hot oil can cause painful burns. Use caution when changing the hydraulic oil.
- Oils can irritate and damage the eyes, throat and other sensitive skin. Avoid contact.
- Petroleum based oils are hazardous to the environment.
Take special care not to spill or discharge these fluids.
Use approved containers and methods to handle and dispose of them.
- Use an authorized disposal and recycling company.

Work Site Precautions

▲ WARNING!

Know the location of any flammable gas lines in the construction area.

Damaged gas lines could lead to a fire or explosion. Operation the breaker may create sparks that could ignite highly flammable gases.

- Never operate the breaker in an environment where highly explosive gases could be present.
- Make sure there are no sources of flammable gases in the work area.
- Always provide sufficient ventilation when working in buildings or confined areas.

▲ WARNING!

Never operate the breaker in the vicinity of explosives.

- Make sure there are no explosives hidden in the rock or stones being broken.
- The impact of the tool could cause them to explode.

▲ WARNING!

Avoid all overhead cables and electrical wiring when operating the breaker to prevent the risk of electrical shock.

- Any contact with sources of electricity can lead to an electric shock, resulting in serious injury or death.
- Check the worksite for hidden electrical circuits.

Fire Prevention

IMPORTANT! Maintain a charged fire extinguisher on the machine at all times and KNOW HOW TO USE IT!

Prevent combustible debris from collecting in tight corners of the machine. This debris by itself may not cause a fire; however, when mixed with fuel, oil, or grease in a hot or confined space, the danger of fire increases dramatically.

To reduce the chance of a fire starting, follow these instructions:

Clean dust and debris from the machine daily.

- Inspect the machine daily for potential fire hazards and make any necessary repairs immediately.
- Inspect electrical wiring and connections and hydraulic hoses to ensure they are secure and not rubbing against other components.

- Clean up any excess grease and oil accumulation and spillage immediately.
- Use only non-flammable solutions for cleaning the machine or components.
- Store rags and other combustible materials in a safe, fireproof location.
- Before starting repair work such as welding, clean the surrounding area and place a fire extinguisher close by.
- Store flammable fluids away from fire hazards. Do not incinerate or puncture pressurized containers.

Welding and Grinding Work

IMPORTANT! A fire extinguisher should be easily accessible during all welding work.

Welding repairs are to be performed by a trained welder with proper service instructions.

Know the material to be welded and select the correct welding procedure and materials (electrodes, rods, wire) that will provide a weld metal strength equivalent to the parent material.

- Move the machine to a clean, safe area before welding, grinding or using an oxy/acetylene torch on it.
This type of work should only be done in a clean area and not in places that contain combustible liquids, such as fuel tanks, hydraulic pipes or similar.
- Consult the carrier operator's manual before starting welding procedures.
Sensitive equipment may require disconnecting machine electronics.
- If welding the breaker side plates or box housing, remove them from the breaker assembly.
This prevents the possibility of internal damage to the breaker resulting from internal arcing between the cylinder and piston.
- Work with extra care when welding, grinding or torch cutting near flammable objects.
- Welding on painted surfaces releases dangerous fumes and results in a poor weld joint that can result in failure and potential accidents. Always remove paint from areas to be welded.

Work on Painted Surfaces

Heated paint gives off poisonous gases. Therefore, paint must be removed from an area with a radius of at least 4 (10 cm) before carrying out welding, grinding or gas cutting. In addition to the health hazard, the weld will be of inferior quality and strength if the paint is not removed.

Methods and precautionary measures when removing paint

Blasting - use respiratory protective equipment and protective goggles.

Paint remover or other chemicals – use a portable air extractor, respiratory protective equipment and protective gloves.

Grinding – use a portable air extractor, respiratory protective equipment and protective gloves and goggles.

Rubber and Plastics

⚠ WARNING!

When heated, rubber and plastics can give off substances that are hazardous to personal health and the environment.

The following safety instructions must be followed:

- Do not weld or cut with a torch near polymer materials (plastics, urethane, and rubber) without first protecting them from the heat.
- Never burn polymer materials when scrapping them.
- Be careful when handling machines that have been exposed to fire or other intense heat. Always use gloves, protective safety glasses and breathing protection.

Hazard Alerts

⚠ WARNING!

The breaker should only be mounted to excavators whose lifting capacity is greater than the minimum value.

⚠ WARNING!

When working overhead, always be aware of the possibility of falling blocks or material fragments. Ensure that the machine is equipped with the necessary protection and that the cab is of the F.O.P.S. (Falling Object Protective Structure) type.

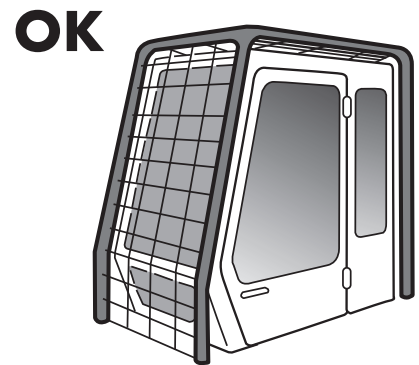

⚠ WARNING!

Keep a minimum distance of 100 ft (30,5 m) from the excavator operating area.

Protect bystanders from the working area to prevent injuries. Proceed carefully when moving the excavator.

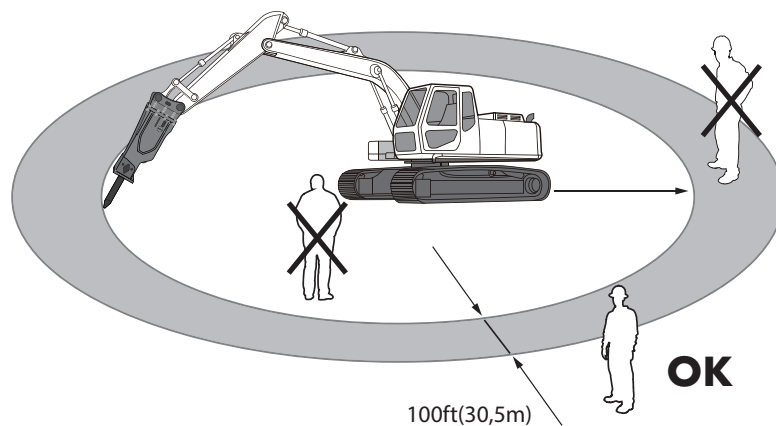

⚠ WARNING!

The breaker must only be used by a skilled operator who has read and understood the Supplier's.

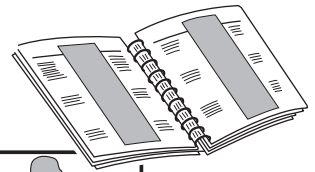

⚠ WARNING!

Do not allow any unauthorized person to operate or carry out any type of maintenance.



⚠ WARNING!

The breaker must be used only on the condition that it has been installed correctly using the attachment bracket and pins.

⚠ WARNING!

Do not use the breaker for lifting, hammering, or transporting materials.

⚠ WARNING!

If the breaker becomes entangled in the reinforcement bars of the structure being demolished, free it before proceeding.

⚠ WARNING!

Do not begin demolition work from lower parts of a structure. The upper part could collapse.

⚠ WARNING!

Do not use the breaker to hammer against the structure being demolish. .

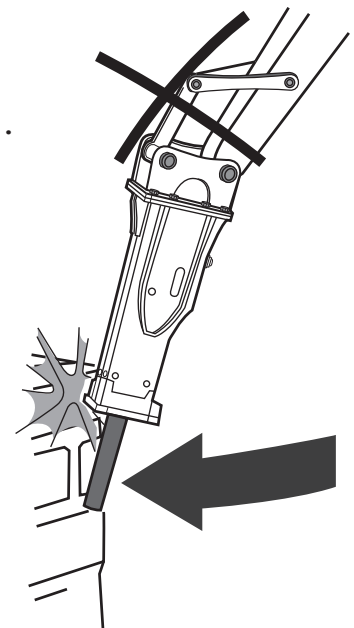

⚠ WARNING!

The excavator boom must be moved safely with slow, accurate movements. Avoid sudden movements.

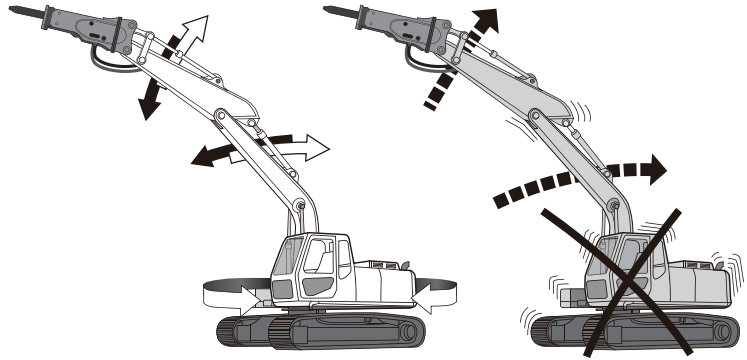

⚠ WARNING!

Ensure that the structure supporting your machine is strong enough to support its weight. Danger of falling!

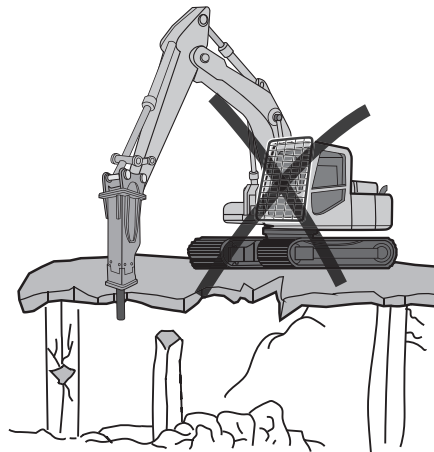

⚠ WARNING!

Stay a minimum of 30 ft(9,1m) away from overhead wires with any part of the machine.

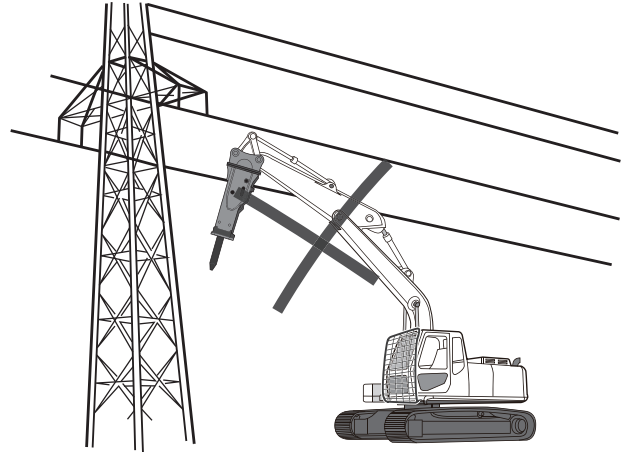

⚠ WARNING!

To keep dust at a minimum during operation, spray the work area with water.

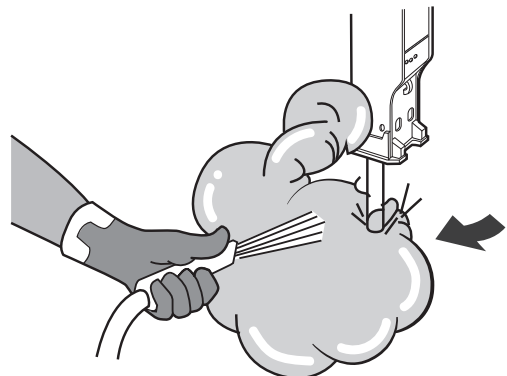

▲ WARNING!

No adaptations or modifications to the breaker are allowed unless agreed upon by Supplier engineering. Written approval must be received beforehand.

Check the carrier Supplier's. Further precautions may be required.

▲ WARNING!

All operations of adjustment, maintenance, repair or cleaning must be made with the engine OFF and the attachment resting firmly on the ground.

Fasten a "DO NOT OPERATE" or similar tag in the cab.

▲ WARNING!

When carrying out maintenance or transporting procedures, take care to place the breaker in a stable position.

The relative movement of various parts should be prevented using ties, supports, blocks etc.

▲ CAUTION!

Use only original Supplier spare parts.

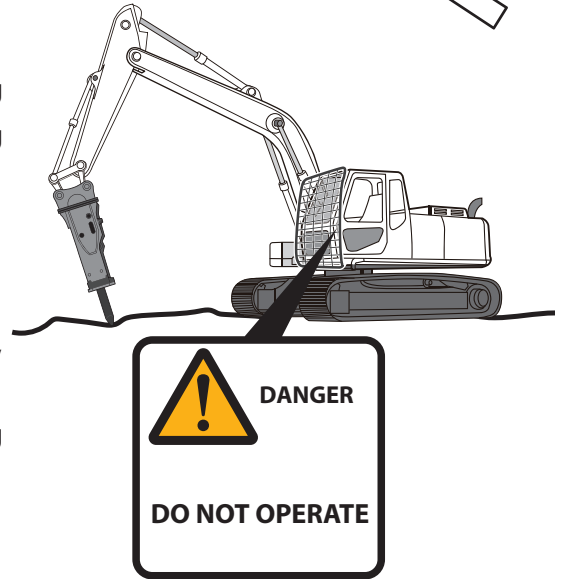
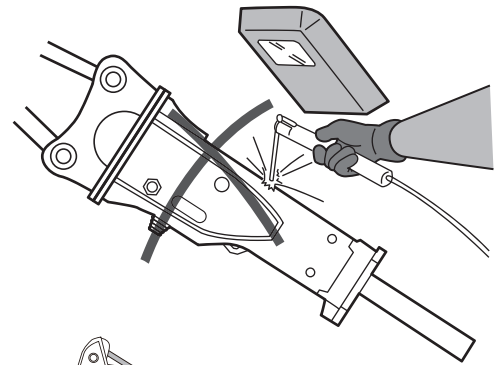

Transporting Safety Precautions

- Use a pressure washer to remove any loose gravel, mud or debris from the breaker and/or carrier.
- Load and unload the machine on a level surface.
- Ensure that the combined height of the trailer bed and the top of the machine cab is lower than local height restrictions or any bridges, overpasses or overhead obstructions expected to be encountered during transport.
- Ensure that the transporting equipment is adequate to hold the weight and size of the machine.
- Place chocks against the truck and trailer wheels.
- Use a ramp or loading dock. Ensure that the ramp is strong enough and has a low angle of rise to the height of the trailer bed.
- Do not place tie-down cables or chains over or against hydraulic tubes, hoses, cylinders or valves, etc. Fasten chains or cables to machine frame.
- Obey all local laws concerning loading, unloading or transporting the machine.
- Keep the trailer bed clean.
- Always keep bystanders clear of the area.

Installation

General

To obtain the best performance from a Supplier hydraulic Breaker, it must be installed correctly and the carrier machine supplying the hydraulic power must be operating properly.

The following checklist will assist in the installation:

- 1) Make sure the hydraulic circuit targeted for the breaker matches the requirements for hydraulic flow and pressure relief settings.
- 2) The hydraulic tubing and hose size must match the requirements of the breaker.
- 3) The hydraulic oil and filter must be clean. Be sure the hydraulic reservoir is full at all times.
- 4) Make sure any hoses or tubes that are used are routed to prevent rubbing or chafing during operation.

It is beneficial for the tank return line to pass through a filter. This ensures dirt introduced into the system by connecting and disconnecting the breaker is caught before entering the carrier's pump

Quick disconnects on the pressure and return lines are not recommended.

If they fail, metal particles can cause internal damage in the breaker such as accelerated component wear, blockages, and seizing. They will also cause a pressure drop and flow restrictions.

▲ CAUTION!

Make sure the hose fittings are clean and dust-free.

▲ CAUTION!

Be sure the operating pressure values do not exceed those instructed in this manual.

▲ WARNING!

It is advisable to provide clearly marked shut-off valves in the breaker pressure and return line circuits.

Shut-off valves will enable them to be isolated when removing or installing the breaker. This will overcome the risk of releasing high-pressure oil and limit the discharge of oil from the hydraulic lines.

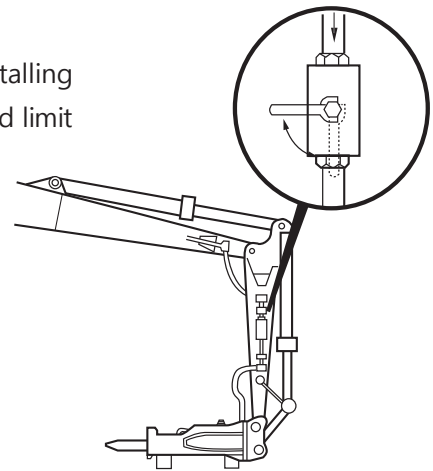

Mounting the Breaker

- 1) Clean the inner surfaces of the breaker attachment bracket with a cloth.
- 2) Draw the carrier machine near inserting the STICK boom into the breaker attachment bracket.
- 3) Carefully clean any dirt from the pins and bushing. Insert the bucket pin checking its alignment and securing it with the collars and locking bolts.

▲ CAUTION!

Do not force the pin; re-check its alignment instead.

- 4) Move the LINK cylinder to line up the hole of the connecting rod with the second mounting bracket attachment hole. Insert the pin and secure it with the collars and locking bolts.

Setting Flow and Pressure

See "Standard Specifications - Page 4" for operating pressure and oil flow requirements for all Supplier models.

▲ CAUTION!

DO NOT operate the breaker below its minimum flow rate. Internal damage to the breaker may result.

DO NOT operate the breaker at a pressure near to or above the relief valve setting. Internal damage to the relief valve may result. Ensure the relief valve is set 400-600 psi (27-41 bar) above the actual operating pressure of the breaker.

Setting the Flow

- 1) Install an in-line flow meter in place of the breaker.
- 2) Adjust the flow on the flow control valve to the maximum permitted for the breaker.
The highest flow will permit the most blows per minute.
- 3) Ensure the flow is within the permitted range.

Setting the Relief pressure

- 1) Connect a flow and pressure meter in place of the breaker.
(Bypass the hydraulic breaker and route the return line directly to the tank.)
- 2) Measure the flow under no load and verify it is in the range for the breaker.
- 3) Slowly increase the pressure and at the same time, verify the flow remains constant right up to the predetermined relief setting.
- 4) Adjust accordingly. Double check both relief pressure and flow settings.
- 5) When the breaker is installed and the oil is warmed to operating temperature, use a pressure gauge in the pressure line to verify the average operating pressure is within the specification.

Start-up

Before putting the breaker to work in hard material, it is necessary to remove air from the hydraulic system and allow the new seals to work in properly.

- 1) Lift the unit off the ground.
- 2) Press the start button or pedal to fire the breaker momentarily.
- 3) Continue to turn the breaker ON and OFF in this manner for 10 minutes.
- 4) Work the breaker in soft material in short bursts for 10 minutes.

5) Check for any loose bolts or oil leakage.

The breaker is now ready to operate.

On new units, be sure the Installation Notice is properly completed and submitted.

Typical hydraulic Circuits

For a hydraulic breaker to function, it needs hydraulic flow and pressure in one direction only.

The supply line should be directed out the left side of the carrier and the return line on the right (as viewed by the operator).

Supplier breakers operate within a specified flow range. The operating pressure will depend on the amount of oil flow, the return line pressure, and internal efficiency of the individual attachment.

Carrier with Auxiliary Hydraulic Circuit

The carrier will often be equipped with an auxiliary control valve. In this case the auxiliary control can be used to control the supply of oil. It can usually be adjusted to provide the correct amount of flow, and a relief cartridge can be installed to protect the hydraulic circuit.

▲ CAUTION!

When using the carrier's existing auxiliary control valve for the hydraulic breaker circuit, do not route the return line back through its return port. High back-pressures may result.

It is recommended to send the oil directly back through the cooler/return filter to the tank.

If it is necessary to plumb the circuit using both ports on the auxiliary valve, the return line should have a drain line connected to the tank. This will reduce back-pressure in the hydraulic circuit and protect the control valve from return line pressure spikes.

Typical hydraulic Circuits

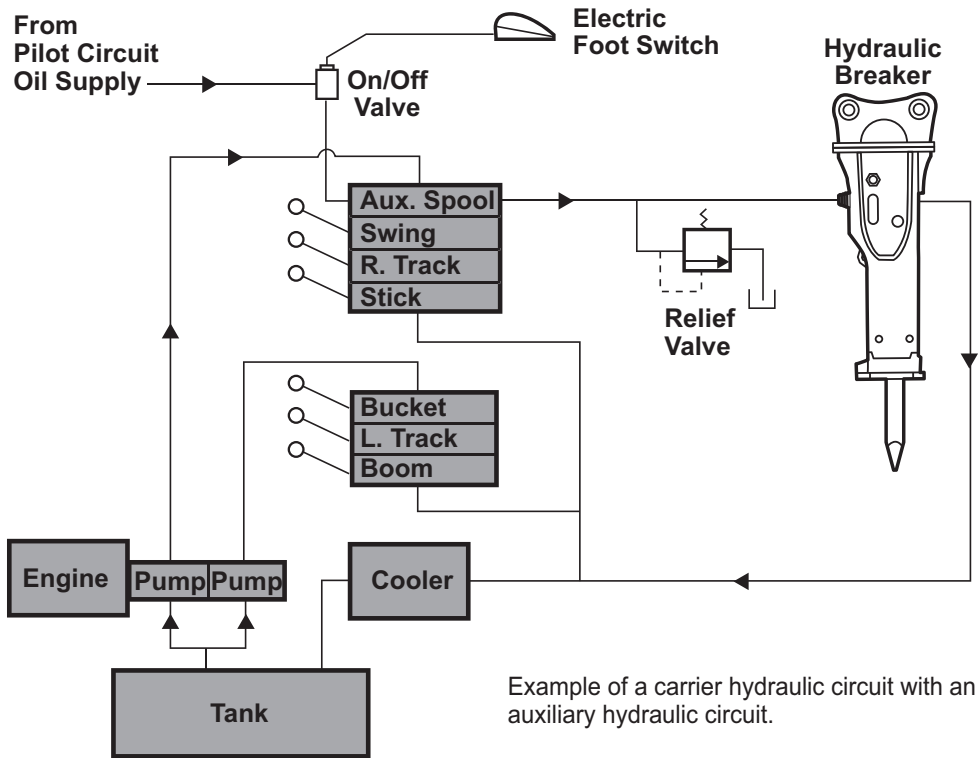

Carrier without Auxiliary Hydraulic Circuit

If the carrier is not equipped with an auxiliary control valve, install a priority flow control valve to direct the correct flow away from the normal circuit and operate the attachment.

The priority flow control valve is usually equipped with a flow adjustment and pressure relief. These valves often need a check valve on the regulated port to completely close the flow. If dividing too much flow, this circuit can generate heat and may require additional cooling capacity.

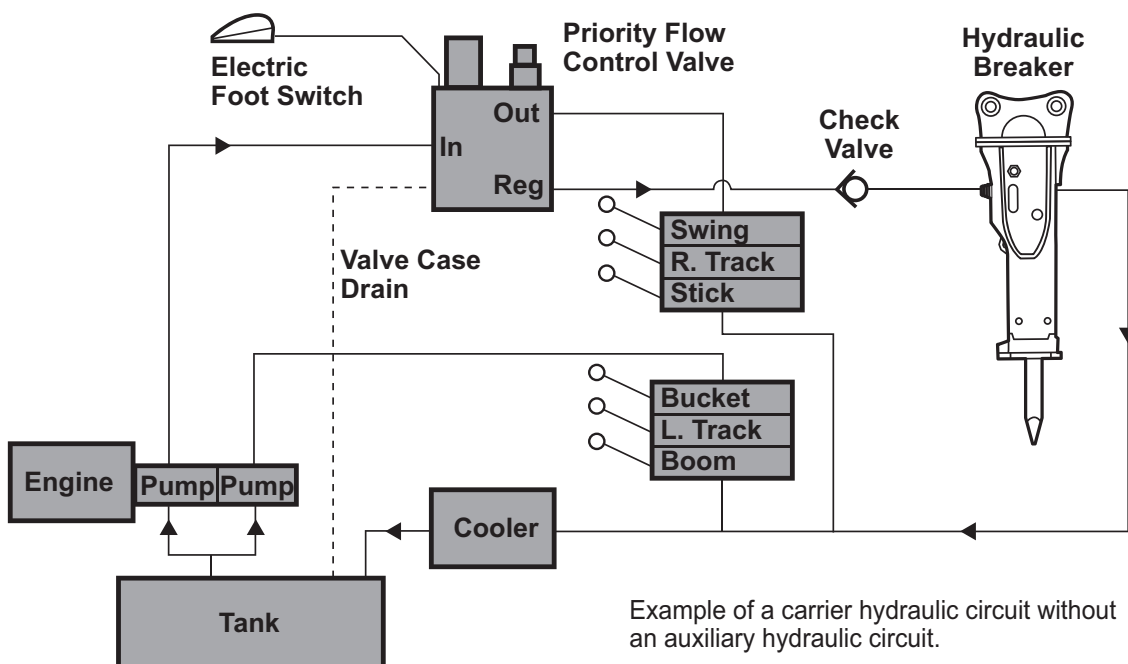

Operation

Suggestions for Efficient Operation

▲ CAUTION!

Do not operate the breaker continuously in one spot for more than 20 seconds. Doing so will cause excessive heat that could mushroom the end of the tool.

- For large rocks, start at the edge and work toward the center, breaking off small chunks each time.
- Always keep the tool 90° to the surface of the rock to reduce side loading on the tool bushings.
- If the rock or stone shows no sign of breaking within 20 seconds, reposition the breaker.
- Breaking along a rock's natural faults and seams makes breaking easier.
- When breaking on a wall or steep incline, use a combination of the carrier's stick cylinder and tilt cylinder to provide the necessary force to hold the breaker against the material. Always work the tool at 90° to the material being broken.
- As down-force is applied on the breaker, the carrier will lift slightly indicating breaker tool is properly pressed onto the material.

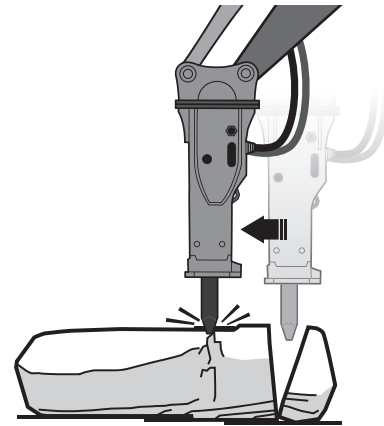

Start at the edge and work toward center.

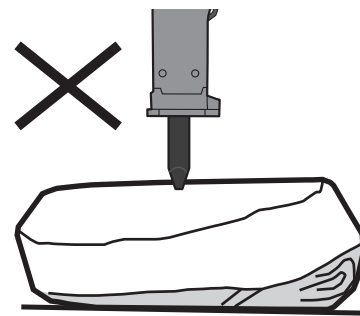

On large rocks, take a smaller bite.
Do not start in the middle.

▲ CAUTION!

The breaker should not be fired when the carrier's boom hydraulic cylinders are fully extended or fully retracted. The cylinders may be damaged from the breaker's shock pulses.

▲ CAUTION!

When hydraulic oil temperature exceeds 158°F (70°C), stop breaking!

If the carrier's operating temperature runs too high, it will actually decrease the breaking power.

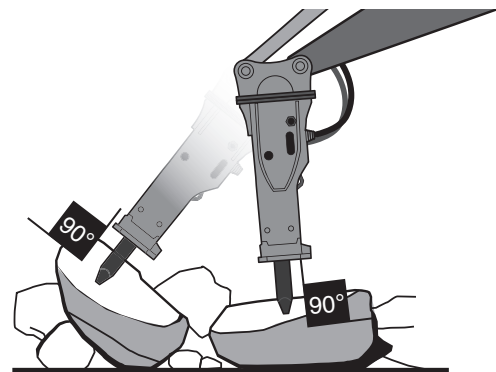

Keep tool 90° to surface of rock.

- Rake ONLY with breaker wear plate and reinforced rock claws. Do not use the tool to rake materials.
- Push ONLY with breaker wear plate and reinforced rock claws.

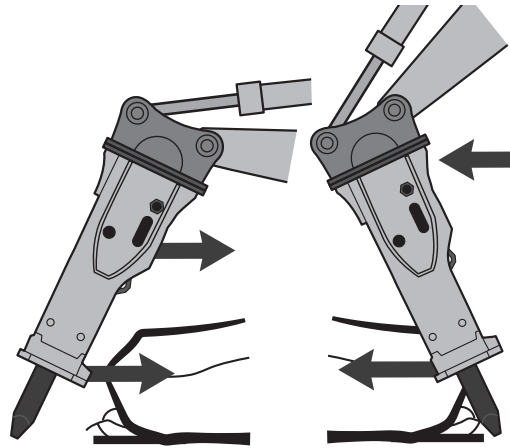

End of Shift

If the breaker is not removed from the carrier at the end of the day, it should be left standing vertical with the tool pushed up into the breaker.

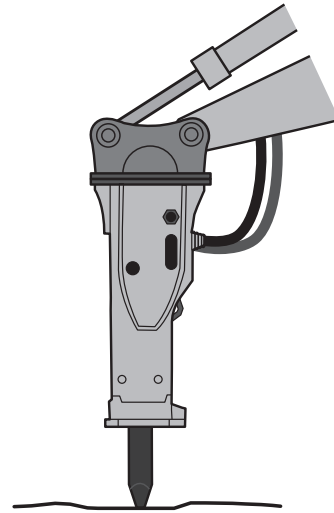

Improper Use of Breaker

▲ CAUTION!

Do not use the breaker to pry, pick, pound, or lift. This can cause serious damage to the breaker as the tool is side loaded or binds in the bushing. The tool must always move freely straight up and down in the bushing.

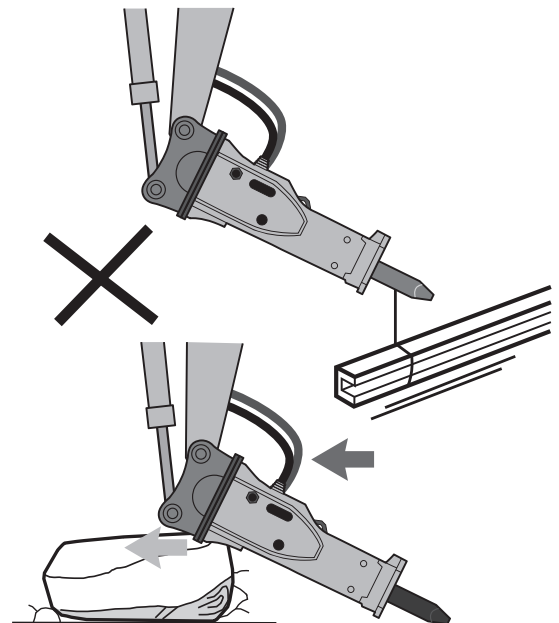

- Do not PUSH incorrectly. Use breaker wear plate and reinforced rock claws.

- Bad alignment BENDS the tool.
Always break at 90° to surface of rock.

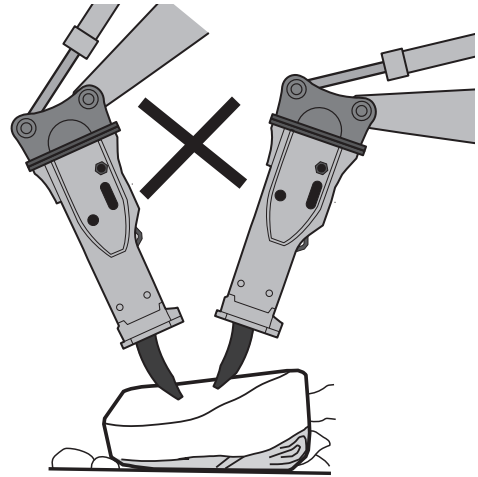

▲ CAUTION!

Excessive down-force will not make breaking easier, in fact the carrier will be lifted too far off the ground and this can damage your equipment.

Not enough down-force and the tool will bounce on the material resulting in blank-firing.

- Do not POUND or PRY with the breaker.

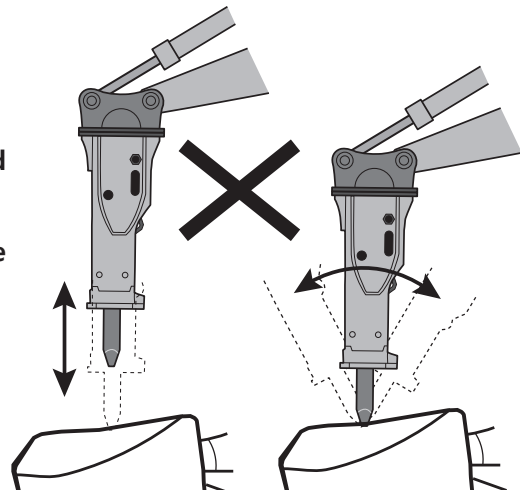

Blank Firing

▲ CAUTION!

Avoid blank firing. Premature failure of parts in the breaker lower end can result. Stop the movement of the breaker's piston when full contact to the target material is lost.

This reduces the strain on the tool retainers and front head during normal operation.

Blank firing emits a distinct metallic ringing sound and most often occurs in hard rock, just as the rock shatters under the tool. With no material under the tool, the piston smashes the ing force back through the breaker and excavator.

This can cause premature failure of the parts in the lower end of the breaker.

To prevent blank firing, learn to anticipate when the material will break. Predicting this moment is probably best done by listening to the sound of the tool hitting the rock. A change in the hammering sound is noticed as the tool breaks through. This is the point to stop firing the breaker.

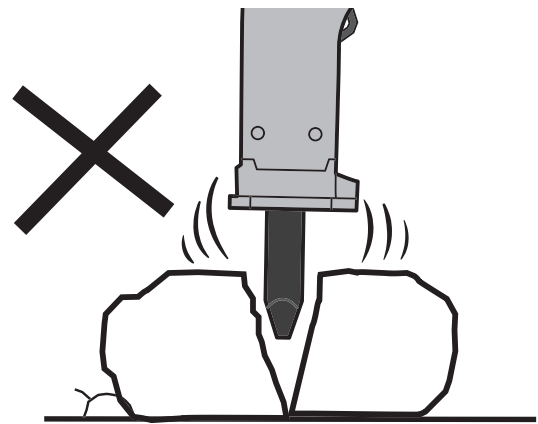

Breaking Oversize Material

With practice, the best place to begin breaking will be learned by just looking at the rock.

- Position the tool on flat areas of the rock, or look for a seam or crack, which may allow easier splitting.
- To fully absorb all the breaker's energy, make sure the rock is resting on a solid base.

Trenching and Excavation

- Before trenching, remove all overburden material, exposing the rock surface to be broken.
- To begin, penetrate the breaker tool deep into the material, splitting and loosening the rock.
- Repeat this penetration several times within a small area, excavating a hole.

When excavating a deep trench it is more effective to use steps or benches allowing a place for the rock to break out to.

- Maintain the benches as the trench advances.
- Slope the sides of the trench to accommodate the width of the breaker.

The larger the breaker. The larger the breaker and the deeper the trench, the wider the opening at the top will need to be.

- For most situations, the excavator will sit to the side of the trench allowing you to keep steeper slopes.

However the carrier swing function may not have the strength to push broken rock away from the work area.

In some cases the excavator can sit on top of the trench and the broken material can be back filled under the excavator.

- For best performance, apply the down force in line with the tool, repositioning every 10 to 15 seconds or when no penetration is evident.
- Keep the breaker well greased at all times.

Breaking Concrete

- Begin by penetrating the concrete several times in one area with the breaker tool.

This should loosen the concrete and separate the reinforcing steel.

This rebar may need to be cut to keep the concrete pieces manageable for removal.

- When breaking concrete floors, use the down force from the carrier's boom cylinder to follow the tool through the concrete.
- For vertical walls, force must be maintained using a combination of boom, stick, and tilt cylinders.

A fast blow rate gives the best performance in breaking concrete, so ensure your carrier is providing the breaker with the maximum recommended oil flow.

Generally, a chisel point gives the best splitting action when breaking concrete. However if breaking hard concrete with lots of rebar, amoil point may be better. Themoil tip helps deflect the tool off the steel as it breaks the concrete.

Breaking on a Grizzly

NOTE: Breaking on a grizzly can cause excessive blank firing. It is recommended the breaker be configured for anti-blank firing mode.

If the grizzly is covered with rock, use the breaker's reinforced rock claws and the wear plate of the box housing, to rake the material. This will get most of the finer material through the bars and let the larger pieces rest directly on the grizzly.

Large pieces are easier to break if they rest directly against the grizzly bars. All the energy from the breaker is then applied directly to the rock. Breaking oversize is less effective when there is material under the rock that can absorb energy.

If rocks are hanging on the edge of the bars, use short bursts of the breaker to hammer them through.

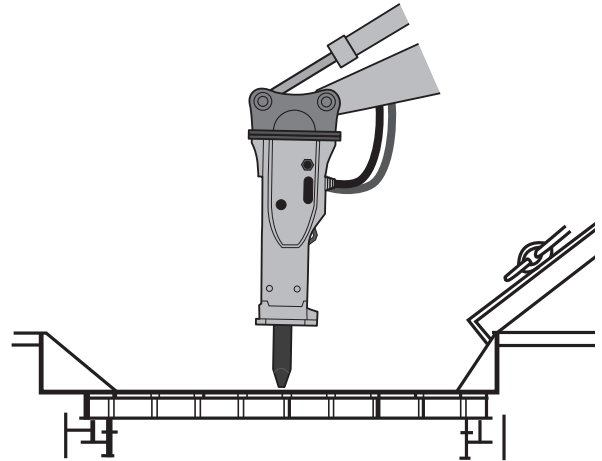

Guide to Tool Choice

- 1) Moil-used for penetration in low abrasive materials of similar make-up.
- 2) Chisel-X – used for splitting material made up of substances that have a different make-up.
- 3) Chisel-Y – Use for asphalt cutting.
- 4) Blunt- Used for impact in hard, crumbly rock.

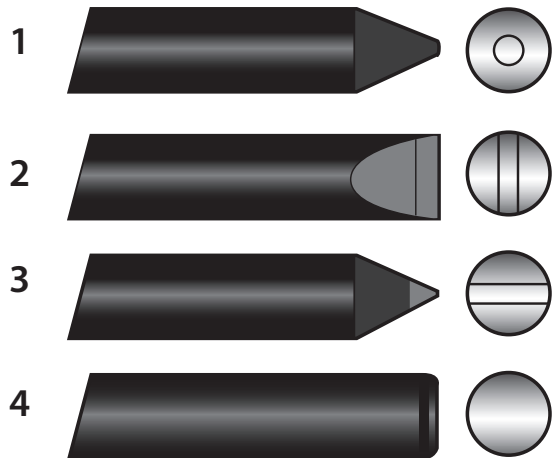

⚠ CAUTION!

Use of after-market tools not approved by Supplier and may void warranty.

Underwater Operation (Optional)

⚠ CAUTION!

Do not operate the breaker underwater or in mud. Permanent damage to the breaker may result.

Supplier breakers require specific modifications for underwater applications.

- Underwater operation of the breaker is possible to pour air into the striking area between the piston and the rod.
- For the sake of underwater operation the adapter is supplied as a standard part.
- For the sake of underwater operation breaker is installed the air supply kit separately.
- Underwater usage of the breaker without the underwater kit and air compressor will cause serious damage to the hydraulic breaker.

Installing the Air Supply Kit

- 1) Clean the air check valve hole on the left-side of the cylinder.
(Except RB505, the air check valve hole is located on the right-side)
- 2) Remove the air check valve with the standard tool.
- 3) Apply the O-ring to the cylinder's air check valve hole and install it.
- 4) Connect the hose to the air check valve hole and install it.
- 5) Before underwater operation, the breaker get into water pouring air into air check valve.

Air flow rate for underwater operation.

The air capacity levels are in the following chart. Supply appropriate air flow rate in accordance with the breaker model and operating depth.

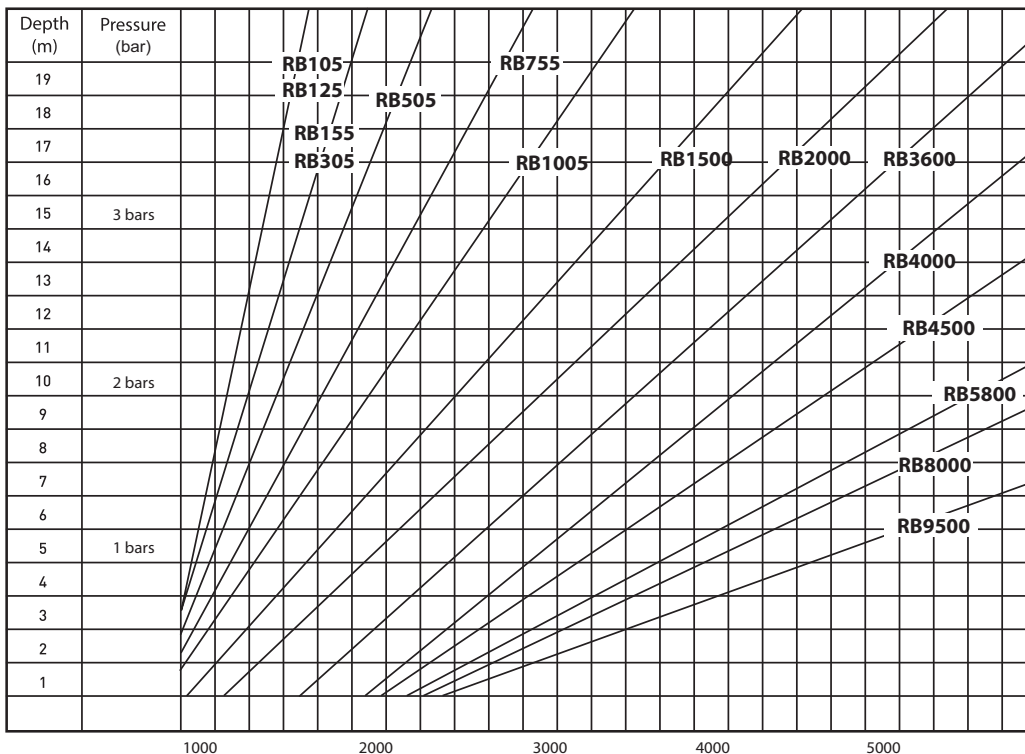

**Illustration for Installing the Underwater Breaker
RB105-RB9500**

No.	Part Name	Q'ty
1	O-Ring	1
2	W-Adapter	1
3	Hose	1
4	Air Check Valve	1

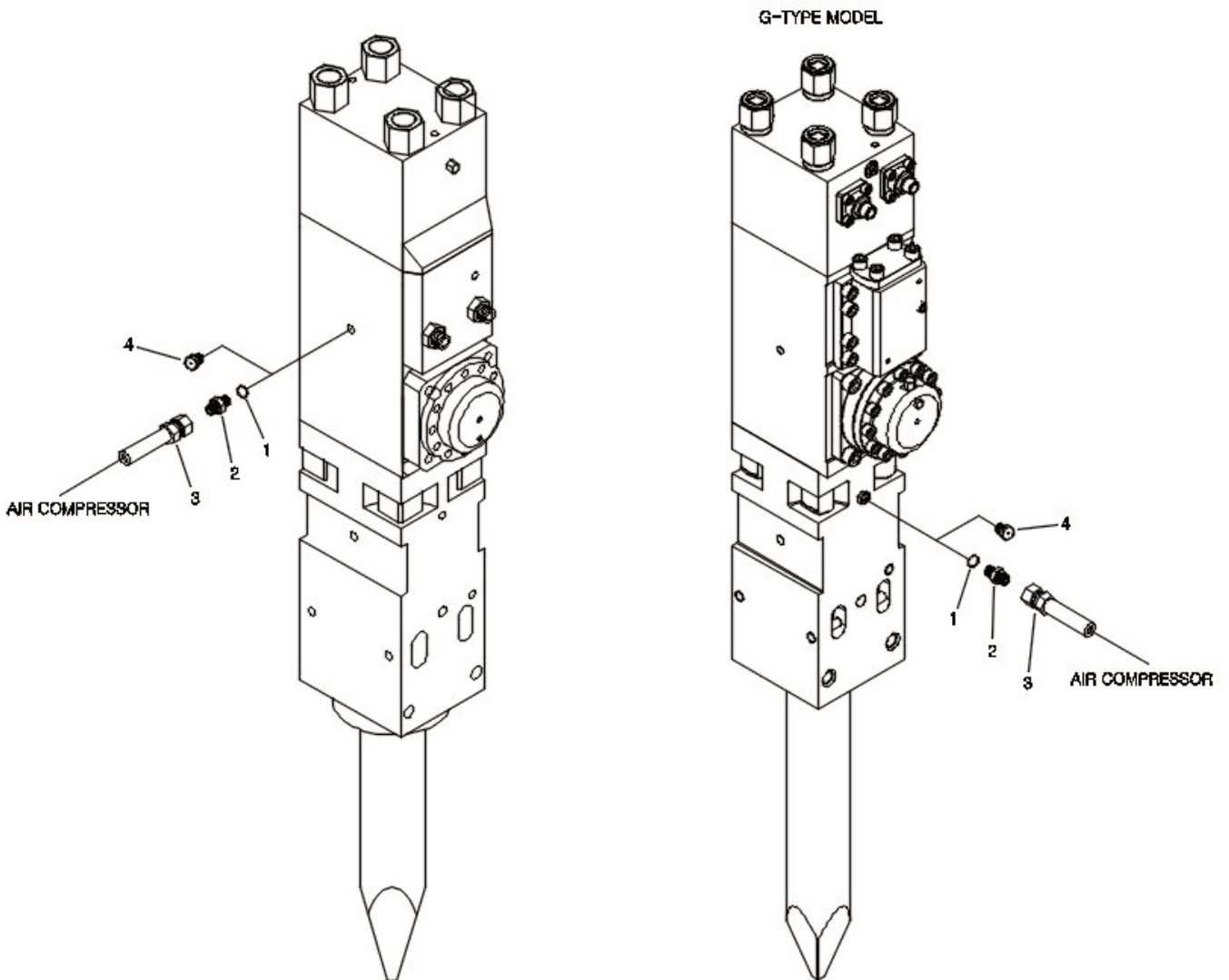

RB105-RB9500

High/Low Speed Selector valve

Breaker models RB1500 and larger can operate at two speeds.

The higher speed setting is obtained by shortening the piston stroke. At the higher speed, the breaking power is somewhat lower, but higher production rates can be achieved in softer materials such as concrete. It is not available on models smaller than RB1500. To set lower speed, turn valve adjuster counter clockwise 2 1/2 turn. To set higher speed than the normal factory setting, turn clockwise 2 turn or more.

A Valve adjuster (1) found on the upper side of the breaker cylinder body is used to switch between high speed and low speed.

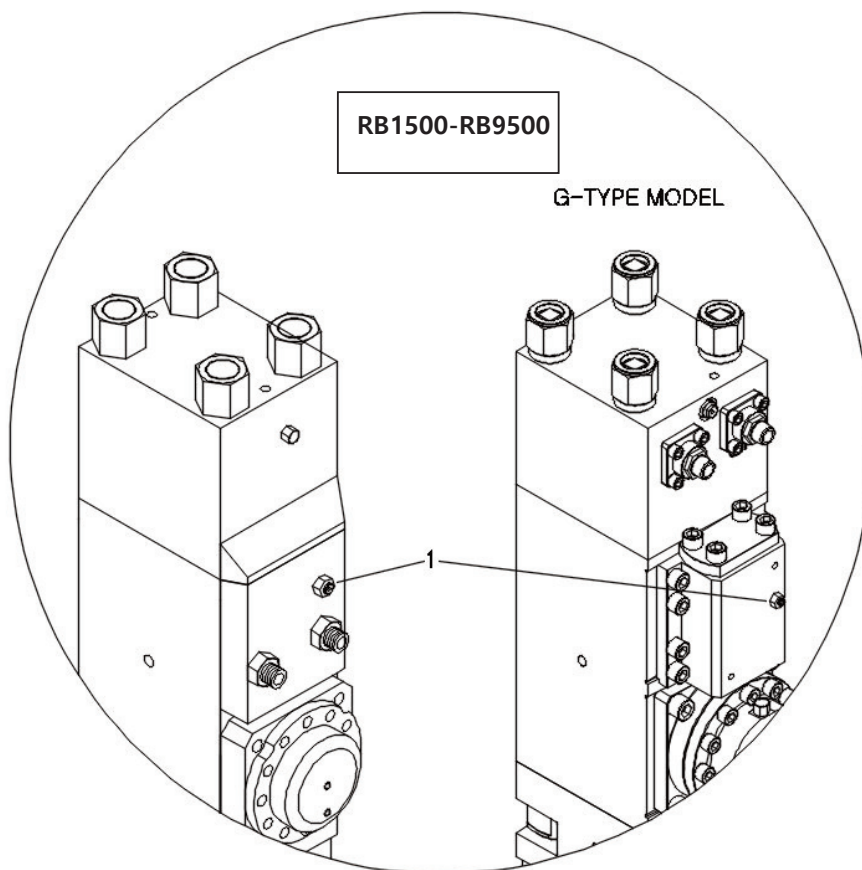

Maintenance

Lubrication is the single most important procedure for sustaining the life of a hydraulic breaker.

To keep your breaker in top operating condition, perform the maintenance procedures outlined in this section.

Greasing the Breaker

▲ CAUTION!

Use proper grease. Always use Supplier chisel Paste or a molybdenum disulfide based (MoS₂) grease to lubricate the tool.

The use of GP (general purpose) grease is not recommended.

It will melt and run down the tool providing very poor lubrication. Use only as a last resort.

Pressing the tool up inside the breaker prevents excessive grease entering the impact chamber.

The excessive grease will cause a cushioning affect and a lack of breaker power when the breaker is fired.

Excessive grease could contaminate the oil and cause seal failure.

- 1) The breaker must be in a vertical position to grease, with enough down-pressure to push the tool up inside the housing.
- 2) Grease until clean grease oozes out around the tool and retainer pins.
- 3) Grease the breaker after every two hours of continuous use, or when the tool appears shiny where it rides inside the front head.

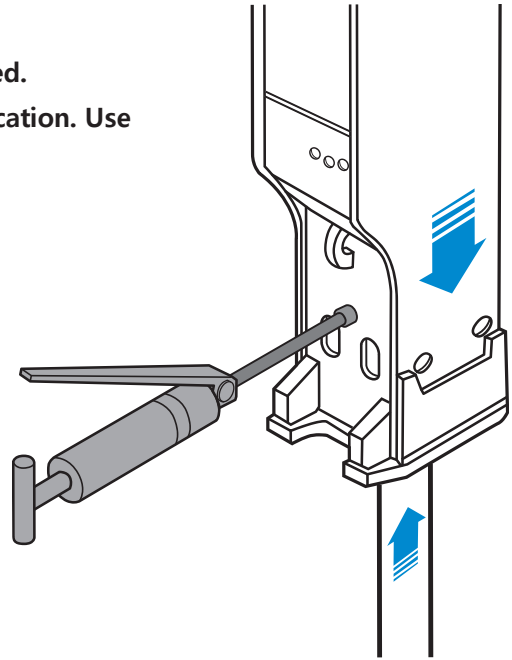

▲ CAUTION!

Grease often. Failure to lubricate regularly reduces the life of the tool, bushings, and front head.

If the tool becomes dry and shiny during the shift, apply additional grease.

Automatic Greasing Systems

A provision hole for automatic greasing systems is provided RB1500 and larger models.

When greasing with an automatic greasing system, the grease should only be injected into the breaker when it's firing. This will allow the breaker to consume the grease correctly.

Set the flow rate so there is a continuous new grease shine near the top of the tool coming from the breaker.

If the tool appears shiny, the greasing flow rate may need to be increased. This rate may change due to specific operating conditions.

Comparison of Automatic Lubrication Systems to Manual Lubrication

Automated Lubrication	Manual Lubrication
<ul style="list-style-type: none">• Constant lubrication	<ul style="list-style-type: none">• Inconsistent lubrication
<ul style="list-style-type: none">• Lube while machine runs	<ul style="list-style-type: none">• Cannot lubricate while operating
<ul style="list-style-type: none">• Closed system-no contamination	<ul style="list-style-type: none">• Constant contamination
<ul style="list-style-type: none">• Extended bearing life	<ul style="list-style-type: none">• Premature bearing failure
<ul style="list-style-type: none">• Less downtime	<ul style="list-style-type: none">• Labor expense
<ul style="list-style-type: none">• Quick payback on investment	

Seal & O-Ring

Since hydraulic breaker operates at high-pressure and high-temperature, leakage or scratch could be occurred by friction, wear and breakage of seals.

Considering pressure, temperature, viscosity of oil, a little leakage is accepted to be normal. But in case of abnormal leakage, replace as a new ones.

To prevent fatal defect periodical replacement is carried out every 3months without external leakage of breaker.

Although the breaker is not operated in a long time, replace seals periodically to prevent rust, corrosion of oil and transformation of seals.

Wear Limit (Front Cover / Ring Bush / Rod Pin / Chisel)

Wear tolerance of each kind expendable parts come to decide. The usage of exceeding the wear tolerance causes fatal damage to breaker. Prevent the damage through the regular inspection and exchange of expendable parts including seals and all kinds of bushes. Our company is not responsible for the flaw using in exceeding the wear tolerance of the expendable parts.

Unit : mm

Model	Front Cover (Lower Bush)		Ring Bush (Inner Bush)	
	New (inside dia)	Wear Limit (Inside diameter)	New (A/B)	Reject (A/B)
RB105	40	42	40/11.1	42/9.0
RB125	45	47	45/10.3	47/8.0
RB155	53	56	53/8.5	55/6.0
RB305	60	63	60/19	62/16.0
RB505	68	72	68/10.5	71/7.5
RB755	75	79	75/20	78/17.0
RB1005	85	89	85/25	89/22.0
RB1500	100	104	100/17	105/14.0
RB2000	125	129	125/31	130/28.0
RB3600	135	140	135/32.5	140/29.5
RB4000	140	145	140/40	146/37
RB4500	150	155	150/38	156/35
RB5800	155	161	155/46	161/27
RB8000	155	161	155/46	161/43
RB9500	175	181	175/53.5	181/50.5

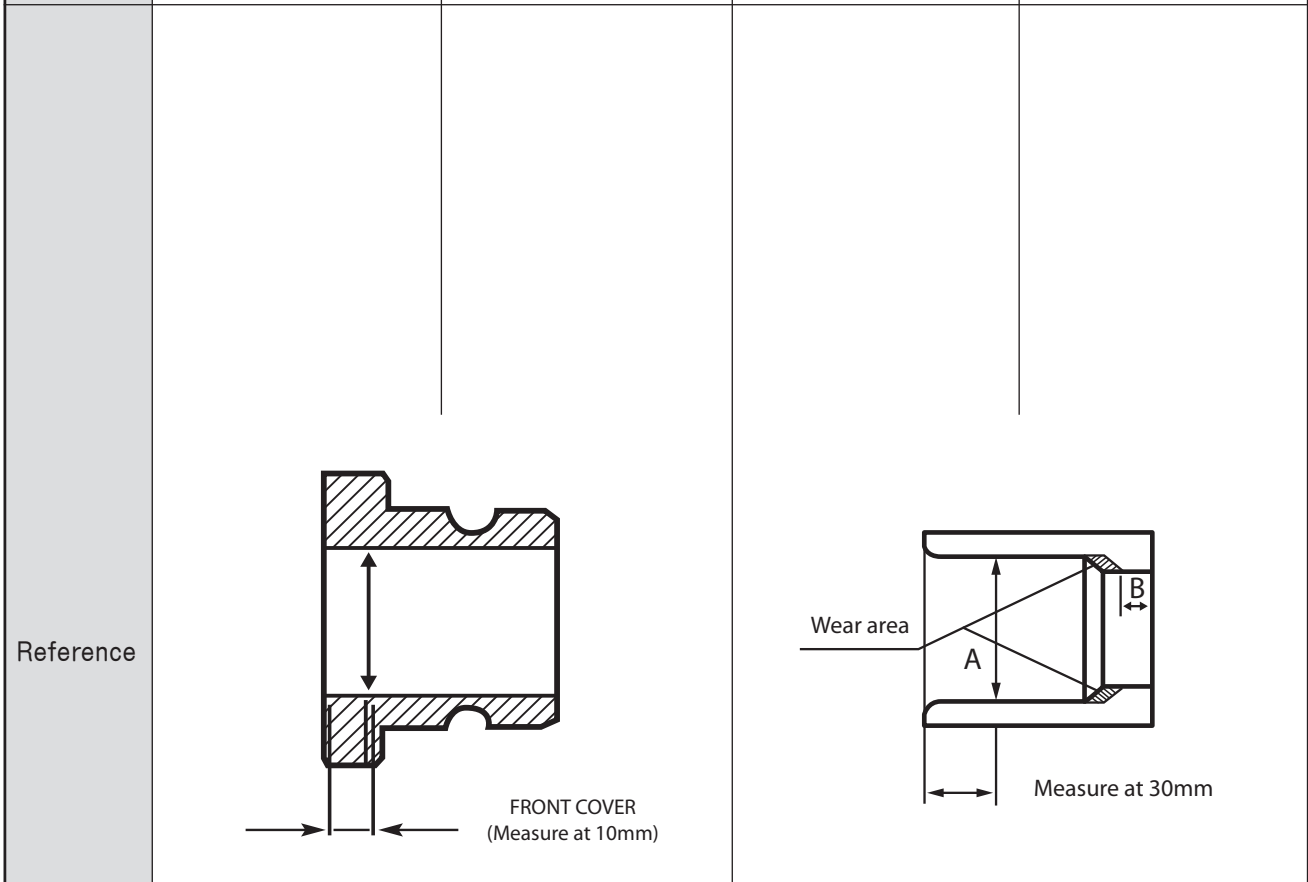

Unit : mm

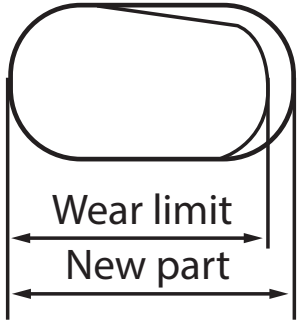
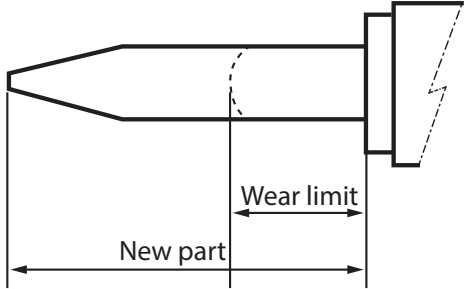
Model	Rod Pin(Tool Pin)		Chisel(Rod)	
	New	Wear Limit	New	Wear Limit
JSB07	22	20	212	140
JSB10	22	20	300	200
JSB20	28	26	326	200
JSB30	32	30	330	200
JSB35	28	26	358	200
JSB40	38	36	425	250
JSB43	38	36	455	250
JSB45	54	51	565	250
JSB50	60	57	565	250
JSB60	75	72	650	300
JSB70A	83	80	702	350
JSB81A	88.5	85.5	762	400
JSB100	94	92	854	450
JSB121	96	93	913	500
JSB130	96	93	919	500
JSB151	99	95	919	500
JSB20G	80	77	76.2	450
Reference				

Changing the Breaker Tool

Check the wear width between the tool and tool bushing. See table on the previous pages for maximum and minimum permissible wear limit.

Tool and Front Tool Bushing Clearance

Check the clearance between the tool and the front tool bushing every 100 hours. Worm parts may cause misalignment between the tool and the piston.

If the value exceeds those shown in the following table, both front and rear tool bushings must be replaced to prevent damage.

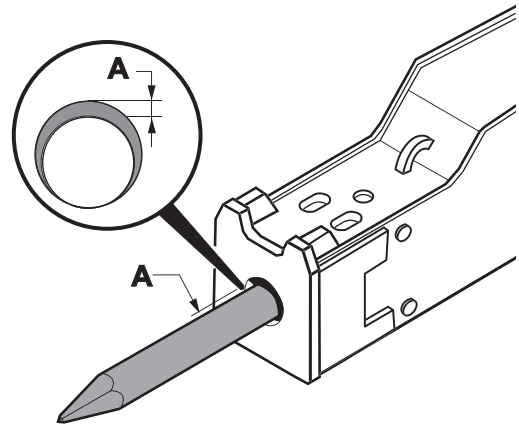

⚠ CAUTION!

Exceeding the following values may damage other component parts, such as the piston and cylinder.

Tool Removal

- 1) To remove the tool, drive out the retainer pin and stopper plug using the drift supplied in the tool kit.
- 2) Use the drift to drive out the tool retainers. Inspect them for cracks or deformities and wear on the edge that rests against the tool.

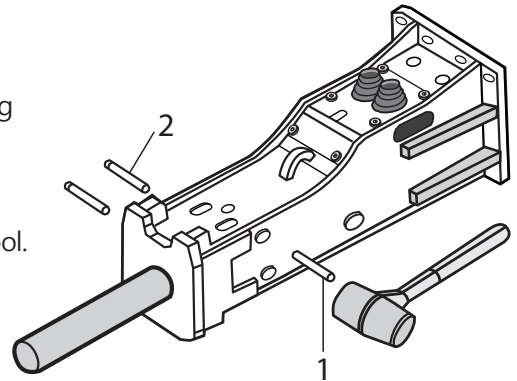

- 3) Remove any burrs on the retainer pins and the tool with a grinder. Check for mushrooming on the top of tool.
- 4) If rotating the retainer pins, make sure the marked surface is towards the tool as shown.

1. Drift
2. Stop Pin/ Retainer Pins
4. Tool Retainer
5. Drift
6. Tool

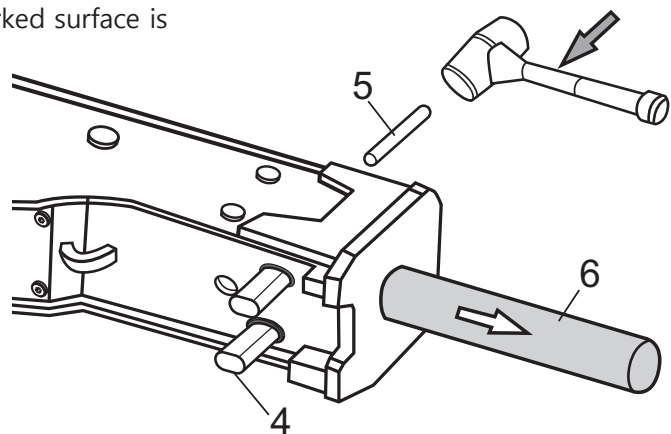

Tool Installation

To install the tool, reverse the above procedure.

- 1) First, grease the inside of the lower bushings.

When the tool is inserted it will take the grease with it.

- 2) Cover the sides of the tool's top section with grease and insert the tool into the front head.

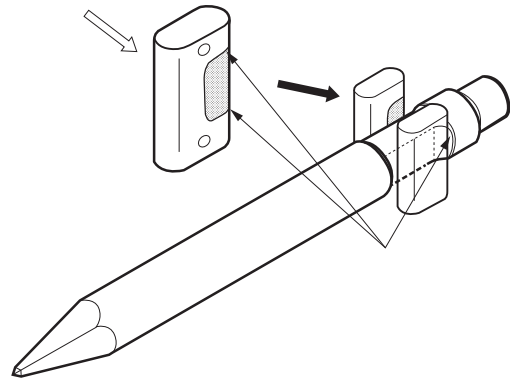

- 3) Grease and insert the tool retainers, then grease and insert the retainer pins.

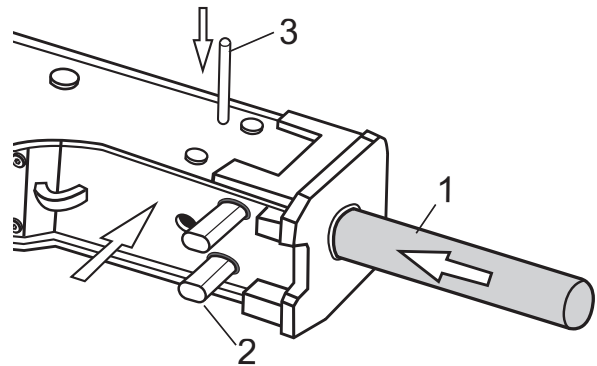

1. Tool

2. Tool Retainer

3. Stop Pins/ Retainer Pins

Cushion Chamber Gas Pressure - Checking

IMPORTANT! Incorrect nitrogen gas pressure in the cushion chamber can damage the breaker and cause poor or erratic breaker behavior.

⚠ CAUTION!

Stay clear of the tool when charging the breaker cushion chamber.

Gas pressure may cause unexpected piston movement and force the tool to jump against the retainer pins.

⚠ CAUTION!

The cushion chamber is charged with nitrogen (N₂) – a non – explosive inert gas.

Use only N₂ when refilling it. Charging it with any other gas could trigger an explosion and lead to serious or possibly fatal injuries.

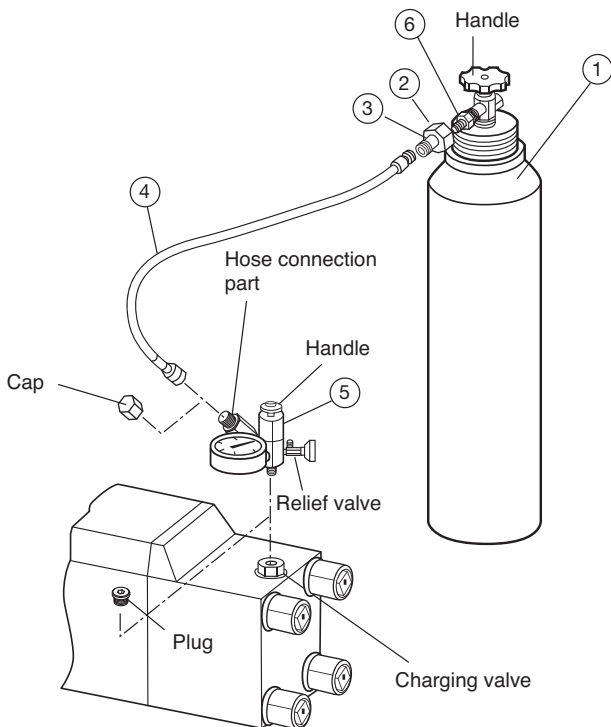

IMPORTANT! Before charging the cushion chamber, make sure the tool is NOT pushed up inside the breaker. Lay the breaker down in a horizontal position.

Item	Part Name	Q'ty
	N ₂ Gas Charging Set	1 SET
1	N ₂ Gas Cylinder	1
2	Adapter Nut	1
3	Adapter	1
4	Synflex Hose	1
5	3-Way Valve Assembly	1

Cushion Chamber(Back Head) Gas Pressure-Checking

- 1) Make sure if the cap and valve of the 3-way valve assembly(5) are fully tightened.
Screw the 3-way valve assembly (5) into the charging valve of the back head after removing the plug.
- 2) At this time the handle must stand up to prevent the gas from coming out.
- 3) Push the handle into the charging valve fully, so the gas pressure inside the back head is indicated on the pressure gauge.
- 4) When the gas pressure is normal, unscrew the 3-way valve assembly after discharging gas inside the 3-way valve assembly.
- 5) When the gas pressure is higher or lower, charge it as described below.

NOTE : Be careful to connect the hose as quickly as possible. Once the hose end is starting to thread on, the valve will unseat and gas pressure can be lost.

Refer to **Specifications** below table for back head gas pressure values.

- Conversion Table for charging nitrogen gas pressure to Back Head

(Depends on the temperature of Back Head surface)

Back Head Surface Temperature (°C/°F)		0 / 32	10 50	20 / 68	30 / 86	40 / 104
Back Head Gas Pressure (kg/psi)	RB105-RB9500	15.5 / 220	16 / 228	16.5 / 235	17 / 242	17.5 / 249

Back Head (Cushion Chamber) Gas Pressure

– Adjusting Increasing the Pressure

- 1) Connect the charging hose(4) to N₂ gas cylinder(1) after screwing the bombe adapter(3) onto adapter nut(2) and installing them to the N₂ gas cylinder.
- 2) Connect the 3-way valve assembly(5) to the charging hose(4) after unscrewing the cap on the 3-way valve.
- 3) Install the 3-way valve assembly(5) to the charging valve of the Back Head.
At this time the handle of the 3-way valve assembly must be up position to prevent the gas from coming out.
- 4) Push the handle of the 3-way valve assembly fully and turn the handle of the N₂ gas cylinder counterclockwise gradually to charge gas.
- 5) When the gas pressure exceeds 10% higher than the specified pressure, close the N₂ gas cylinder by turning the handle clockwise.
- 6) Leave the handle of 3-way valve assembly up. Generated pressure makes it return back to original position naturally.
- 7) In order to discharge N₂ gas in the charging hose(4) and the 3-way valve assembly turn the relief valve counterclockwise.
- 8) Remove the charging hose(4) from the N₂ gas cylinder(1) and the 3-way valve assembly(5), and screw the cap into the 3-way valve assembly.
- 9) Push the handle of the 3-way valve assembly fully, and the gas pressure inside the Back Head is indicated on the pressure gauge. When the pressure is higher, discharge a small amount of gas from the Back Head by repeatedly opening and closing the valve and then gas pressure falls to the specified pressure.
- 10) When the gas pressure reaches to the specified pressure, close the valve and release the handle.
- 11) Open the valve completely and discharge gas inside the 3-way valve assembly.
Remove the 3-way valve assembly from the charging valve of Back Head and install the plug to the charging valve. At this time prevent contamination from entering the breaker.

Torque and Gas Pressure Table

Torque(LB-FT) & Gas Pressure(PSI) Table

Model		RB105	RB155	RB305	RB505	RB755	RB1005	RB1500	RB2000	RB3600
Items		RB125								
M/Body Torque	Through Bolt Hex Nut	215 M18/20/22	255 M24	255 M24	325 M27	505 M30	725 R33	1085 R39	1810 R42	2170/1810 R48/R42
	V/Housing Bolt (12.9T)								435 (M20)	435 (M20)
	V/Cover Bolt (12.9T)								650 (M24)	650 (M24)
	Accumulator Body Bolt (12.9T)								650 (M24)	650 (M24)
	Accumulator Cover Bolt (12.9T)								215 (M16)	290 (M18)
	IN/OUT Adapter	115~130	115~130	115~130	115~130	115~130	175~190	175~190	230~255	230~255
	Valve Adjust Nut								180~215	255~290
	Air Check Valve	115~130	115~130	115~130	115~130	115~130	115~130	115~130	115~130	115~130
	Gas Charging Valve	255~290	255~290	255~290	255~290	255~290	255~290	255~290	255~290	255~290
	Plug									
Bracket Torque	Bracket Side Bolt	435	580	580	725	725	1050	1050	1450	1810
	Mount Cap Bol.t (12.9T)	130 (M14)	130 (M14)	215 (M16)	215 (M16)	215 (M16)	435 (M20)	435 (M20)	650 (M24)	650 (M24) 1010 (M27)
Gas Pressure	Back Head Gas Pressure	220-235	220-235	220-235	220-235	220-235	220-235	220-235	220-235	220-235
	Accumulator Gas Pressure								855	855

Model		RB4000	RB4500	RB5800 RB8000	RB9500
Items					
M/Body Torque	Through Bolt Hex Nut	2530 R52	3255/2530 R56/R52	3255 R56	3615 R58
	V/Housing Bolt (12.9T)		435 (M20)		
	V/Cover Bolt (12.9T)		435 (M20)		
	Accumulator Body Bolt (12.9T)	650 (M24)	650 (M24)	650 (M24)	650 (M24)
	Accumulator Cover Bolt (12.9T)	290 (M18)	290 (M18)	290 (M18)	435 (M20)
	IN/OUT Adapter	230~255	230~255	230~290	230~290
	Valve Adjust Nut	255~290	255~290	360~395	435~470
	Air Check Valve	115~130	115~130	115~130	115~130
	Gas Charging Valve	255~290	255~290	255~290	255~290
	Plug				
Bracket Torque	Bracket Side Bolt	1810	1810	2530	2530
	Mount Cap Bol.t (12.9T)	1010 (M27)	1375 (M30)	1375 (M30)	1375 (M30)
Gas Pressure	Back Head Gas Pressure	220-235	220-235 6	220-235	220-235
	Accumulator Gas Pressure	855	855	855	855

Nitrogen Charging Pressure vs Ambient Temperature

The following table is a guide to back head (cushion chamber) pressure values adjusted to ambient temperature differences.

- Allow the hydraulic breaker and the nitrogen bottle temperatures to normalize to room temperature in a shop environment.
- Adjust the cushion chamber pressure as indicated in the table below for the ambient temperature expected.

Conversion table for charging N₂ gas pressure to back head

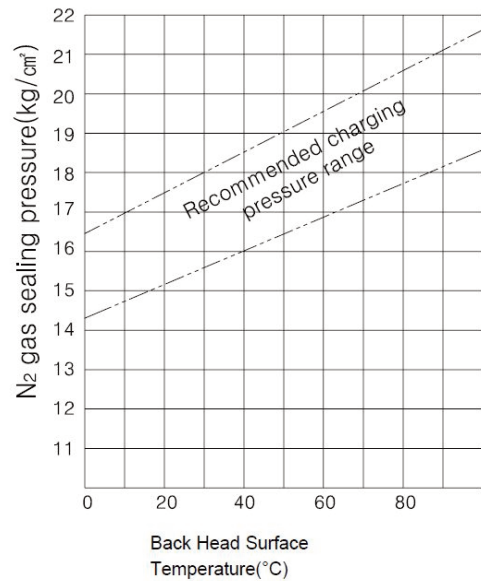

Accumulator Gas Pressure – Checking

Check accumulator gas pressure every 500 hours of operation.

⚠ CAUTION!

The accumulator is charged with nitrogen (N₂) – a non-explosive inert gas. Use only N₂ when refilling it. Charging it with any other gas could trigger an explosion and lead to serious or possibly fatal injuries.

IMPORTANT! Incorrect nitrogen gas pressure in the accumulator can damage the breaker and cause poor or erratic breaker behavior.

IMPORTANT! Hydraulic oil pressure MUST be fully vented inside the breaker before charging the accumulator. Residual pressure will result in an incorrect N₂ charge pressure.

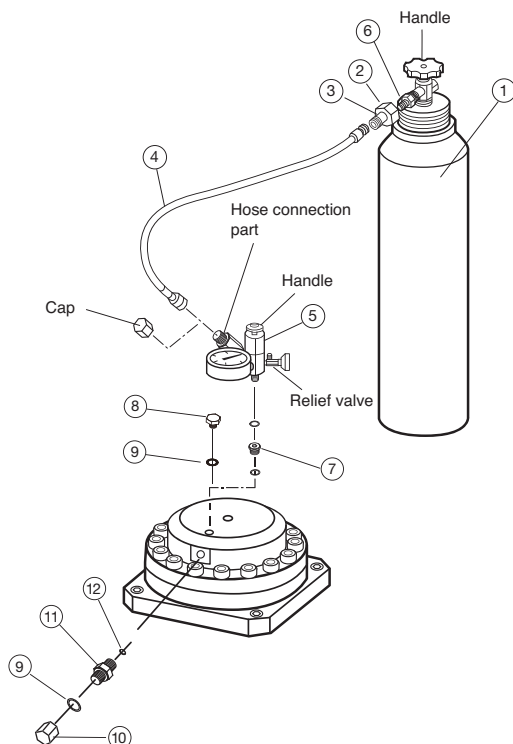

Item	Part Name	Item
	N ₂ Gas Charging Set	1 SET
1	N ₂ Gas Cylinder	1
2	Adapter Nut	1
3	Adapter	1
4	Synflex Hose	1
5	3-Way Valve Assembly	1
6	O-Ring	1
7	O-Ring Hex Bushing	1
8	O-Ring	1
9	O-Ring Plug	1
10	O-Ring	2
11	O-Ring Cap	4
12	Accumulator Charging Valve	1
13	O-Ring	4

Accumulator Gas Pressure – Checking.

- 1) Make sure if the cap and valve of the 3-way valve assembly(5) are fully tightened.
- 2) Remove the cap(11) from the accumulator and tighten the charging valve (12) fully.
- 3) Check if O-rings(6)(8) are installed to the bushing(7). Remove the plug(9) and screw the bushing.
- 4) Install the bushing(7) to the 3-way valve assembly(5).
- 5) Loosen the charging valve(12) gradually. The charging pressure is indicated on the pressure gauge.
- 6) Close the valve clockwise when the gas pressure is normal. If the gas pressure is higher, repeat loosening and tightening the relief valve of 3-way valve assembly. The pressure is lowered gradually.
- 7) Loosen the relief valve of the 3-way valve assembly to discharge the N₂ gas in the 3-way valve assembly(5).
- 8) Remove the 3-way valve assembly(5) and tighten the plug(9) and cap(11).

IMPORTANT! To determine the correct pressure in relation to ambient temperatures, refer to the below table.

- Conversion Table for charging nitrogen gas pressure to Accumulator

Accumulator Surface Temperature (°C/°F)	0 / 32	0 / 32	0 / 32	0 / 32	0 / 32
Accumulator Gas Pressure (kg/psi)	51 / 730	51 / 730	51 / 730	51 / 730	51 / 730

Accumulator Gas Pressure

– Adjusting Increasing the Pressure

- 1) Connect the charging hose(4) to N₂ gas cylinder(1) after screwing the bombe adapter(3) onto adapter, nut(2) and installing to the N₂ gas cylinder.
- 2) Connect the 3-way valve assembly(5) to the charging hose(4) after unscrewing the cap on the 3-way valve assembly.
- 3) Remove the cap(11) form the accumulator and tighten the charging valve(12) fully.
- 4) Check if O-rings (6)(8) are installed to the bushing(7). Remove the plug(9) and screw the bushing.
- 5) Loosen the accumulator charging valve(12) after checking if bushing(7) is installed to the 3-way valve assembly.
- 6) Turn the handle of the N₂ gas cylinder counter clockwise slowly to charge gas.
- 7) Charge gas in accordance with the conversion table for charging N₂ gas pressure to accumulator.
- 8) Turn the handle of the N₂ gas cylinder clockwise to close the cock.
- 9) Close the accumulator charging valve(12).
- 10) Loosen the relief valve of the 3-way valve assembly to discharge the N₂ gas remaining in the charging hose.
- 11) Remove the charging hose, 3-way valve assembly and bushing and tighten the plug(9) and cap(11).

Nitrogen Charging Pressure vs Ambient Temperature

The following table is a guide to accumulator pressure values adjusted to ambient temperature differences.

- Allow the hydraulic breaker and the nitrogen bottle temperatures to normalize to room temperature in a shop environment.
- Adjust the accumulator and cushion chamber pressure as indicated in the tables below for the ambient temperature expected.

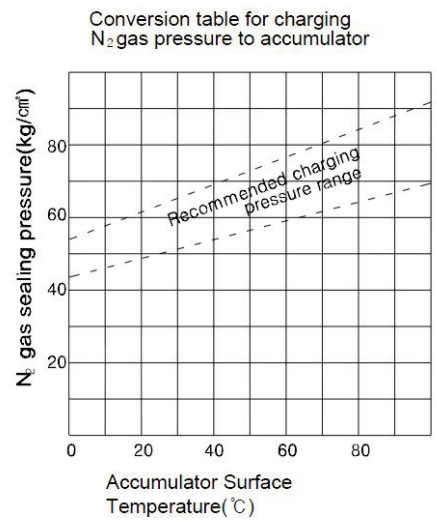

Maintenance Schedule

Pre Shift

	Verify correct operation of all machine functions.
	Check for leaks, damaged hoses or clamps.
	Check that all electrical components are in operational condition.
	Grease the breaker tool, retainer pins and plugs with Chisel Paste. If equipped with auto lube system, ensure there is adequate grease in the reservoir.

Every 2 Hours

	Verify correct operation of all machine functions
	Grease breaker tool bushing. Pump grease in until it is visible around tool and retainer pins.
	Check general condition of machine and surrounding work area.

Every 8 Hours – Daily

	Check all screw connections for tightness (during first 50 hours of operation). Refer to "Torque Specifications"
	Check hydraulic oil level in carrier reservoir.
	Check lubrication system.
	Check all hardware and bolts for tightness.
	Check all hydraulic lines, fittings and clamps for leaks or damage.
	Check breaker for damage, loose fittings, or hydraulic leaks.

Every 50 Hours – Weekly

	Check torque on all fasteners.
	Check mounting pins for wear.
	Check impact surface of tool for deformation.
	Remove the breaker tool and retaining pins. Inspect the wearing surfaces Remove any burrs before reinstalling. Refer to Service section if scuffing marks are found on the tool.
	Inspect upper isolator.
	Use a hammer to ping (knock) the tie rods. The same tone will resonate if the tie rods are torque equally. A loose tie rod will be immediately evident.

Every 100 Hours

	Remove the breaker tool and inspect the wearing surface. Remove any burrs before reinstalling.
	Inspect the tool retainer pins. Remove the pins, rotate 180 degrees and reinstall.
	After initial 100 hours of operation, change hydraulic pressure and return line filter elements.
	Check tool bushing clearance.
	Check that the pressure/return filter indicators on the carrier hydraulic system are functioning correctly and not in by-pass.

Every 500 Hours

	Take a sample of the hydraulic oil. Review the results and determine if an increase in filter change interval and/or oil change is required. File the results.
	Check cushion chamber nitrogen gas pressure. Refer to "Cushion Chamber Gas Pressure – Checking"
	Perform all breaker checks above as required.
	Check that the retainer pins, cross pins and stopper plugs are not damaged and are in place.
	Check that the upper isolator and tie rod nuts are in place and tight. Check for wear.

Every 1000 Hours or Yearly

	Replace the retainer pins.
	Perform all breaker checks listed above as required.
	Disassemble the breaker to replace all seals. Replace upper and lower breaker isolators inside the housing.
	Measure the wear limit on the Front and Rear Bushings. Replace each bushing if the allowable tolerances are exceeded.
	Check Hydraulic flow to breaker and operating pressure. Adjust as necessary.

Breaker Disassembly

⚠ WARNING!

Hydraulic breakers and their components are heavy! Plan carefully how you will handle them when removing, disassembling, or installing the breaker. Stand clear when slinging the breaker off the ground.

⚠ CAUTION!

Use extreme care to prevent dirt from entering the hydraulic circuit when disconnecting or reconnecting hydraulic lines. Cap or plug lines when disconnecting; clean thoroughly before reconnecting. Even the smallest dirt particles will cause damage to the internal workings of the breaker.

⚠ WARNING!

Risk of personal injury! Wear safety glasses, boots, and protective gloves.

Relieve all trapped pressure in the breaker hydraulic circuit. Pressure can be maintained in hydraulic circuits long after the power source and pump have been shut down.

- 1) Relieve all pressure before disconnecting hoses or tubes.
- 2) Use a lifting crane of suitable capacity to remove the breaker from the carrier.
NOTE: Breaker disassembly must be carried out in a clean shop environment.
- 3) Remove the tool from the breaker. Measure and record the clearance value between the tool and the tool bushing.
- 4) Position the breaker upright on a clean, level shop floor surface.
- 5) Restrain the breaker upright in this position while keeping the crane in place. Restrain the breaker with chains, straps or other suitable method to prevent it from tipping over if knocked or hit from an external load (forklift, cranes, loads on cranes, etc.)

⚠ CAUTION!

Be aware of worn housings.

As the breaker is used, the lower portion of the housing becomes worn.

Worn housings can be unstable.

- 6) Ensure breaker is supported and restrained to prevent tipping over.
- 7) The breaker housing must also be restrained against upward movement produced by the lift crane.
- 8) Remove crane rigging from the breaker housing only AFTER the breaker housing has been fully restrained.

⚠ CAUTION!

Upper and lower isolators inside the breaker housing are compressed to provide a preload on the breaker body to support it within the housing.

Loosen bolts gradually and equally to remove pre-load and prevent injury.

9) Loosen top mount bracket bolts gradually and equally to reduce spring pre-load from isolators. Once all bolts have been loosened, the spring pre-load will be gone and it is safe to remove the bolts.

10) Remove top mount bracket bolts and bracket. Store in a safe place away from the work area. If the upper or lower isolators are not thick enough, it should be replaced.

11) Remove the upper isolator from the breaker and check for cracking, heat damage, wear etc. If the isolator is in poor condition it must be replaced.

NOTE: Upper and lower isolators must be replaced after 1000 hours of operation.

Removing Breaker Body from Housing

NOTE: All lifting eyes required for breaker disassembly are found in the breaker tool kit.

Wear Pads

Besides the upper and lower isolators, the breaker body has wear pads between it and the inside of the housing to keep it supported. Wear pads can be reused also, if in good condition.

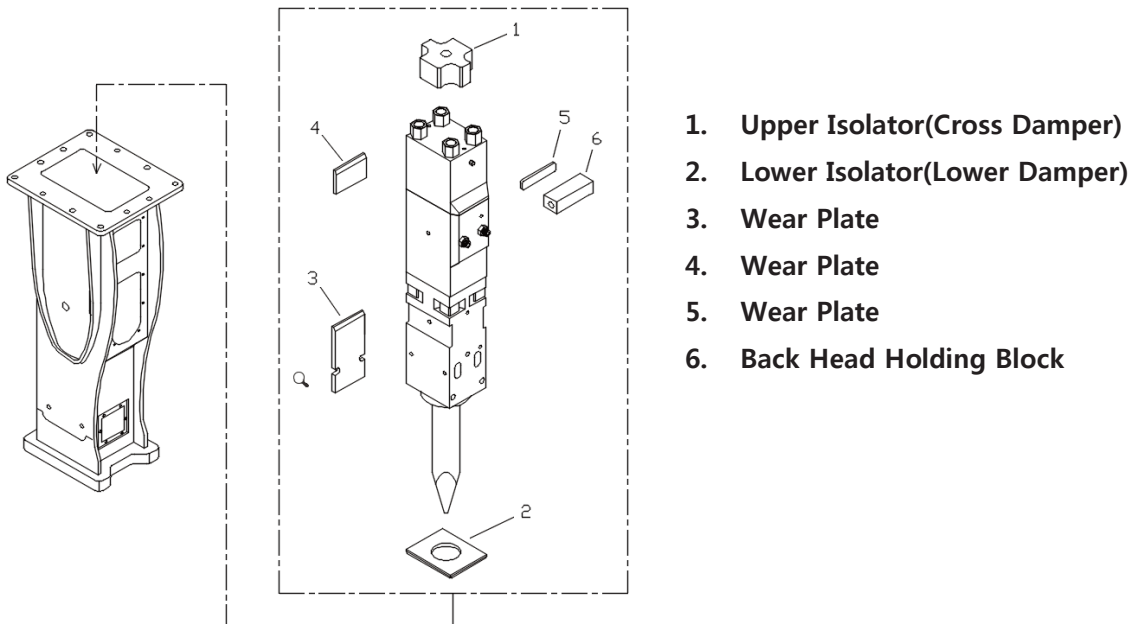

Weight of Main body

Model	Weight (LB)	Model	Weight (LB)
RB105	120	RB1500	1040
RB125	145	RB2000	1440
RB155	185	RB3600	1665
RB305	275	RB4000	2010
RB505	335	RB4500	2365
RB755	465	RB5800	2830
RB1005	620	RB8000	3185
		RB9500	4245

⚠ CAUTION!

Ensure breaker is restrained to prevent tipping over.

- 1) Insert the appropriate lifting eyes into the rear head.
- 2) Using an overhead crane, pull the breaker body straight up out of the housing.
- 3) Carefully lower the bare breaker onto a smooth, clean, level surface.
- 4) Clean inside of the housing. Inspect for weld cracks, damage etc. inside and outside of the housing. Repair as required.
- 5) Clean and inspect the front head area of the bare breaker. Clean and inspect the wear pads.

NOTE: The upper/lower isolators and wear pads are considered wear parts and are not covered under the breaker warranty. It is recommended that they be replaced after every 1000 hours of operation or as required.

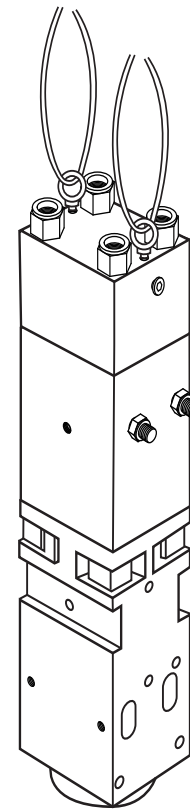

Breaker Body Disassembly

The breaker body can be disassembled standing up or laying down. The following instructions describe the standing method.

⚠ WARNING!

Release cushion chamber gas pressure before disassembly. The cushion chamber in the back head contains nitrogen gas under pressure. Do not remove the tie rod nuts or gas valve until this pressure is released.

⚠ WARNING!

DO NOT use impact tools to disassemble or reassemble the breaker body. The tie rods and control valve bolts use heliserts (steel threaded inserts) that can be damaged by the use of impact tools.

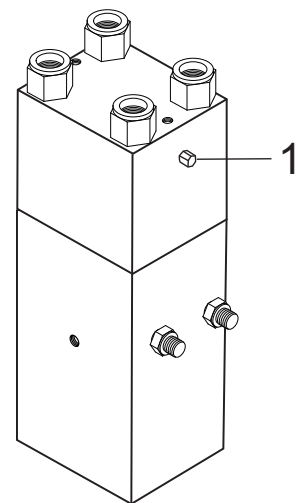

1.Back Head Charging Valve

Rear Head Removal

- 1) Use the charging hose in tool kit to fully vent the N₂ gas from the cushion chamber.
- 2) Insert lifting eyes into the rear head and stand the breaker on a safety stand.
- 3) Remove the back head charging valve to avoid accidental damage during bushing replacement. Put it in a safe place for reuse later.
- 4) Back off the tie rod nuts a couple of turns. This can be done using a torque multiplier if the breaker is standing up. If the breaker is lying down, use the sledge-wrench method.
- 5) Using a hoist, jerk the assembly upwards slightly, which should loosen the rear head from the cylinder.
- 6) Place the rear head on a clean protective surface.
- 7) If the rear head is stuck, it may be necessary to tap the cylinder cover on alternate sides with a soft-faced mallet. Remove the nuts and washers from the four tie rods.
- 8) Remove the rear head from the cylinder using lifting eyes.

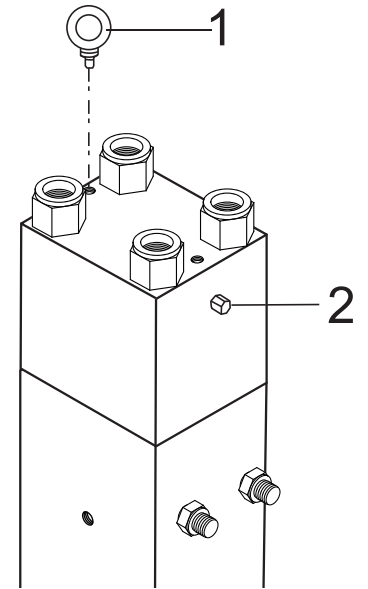

1. Lifting Eye
2. Back head charging valve

In some cases, the nuts may be seized onto the tie rod and may come out as a unit.

Accumulator Removal

▲ WARNING!

Release accumulator gas pressure before disassembly. The accumulator contains nitrogen gas under pressure. Do not remove the bolts until this pressure is released.

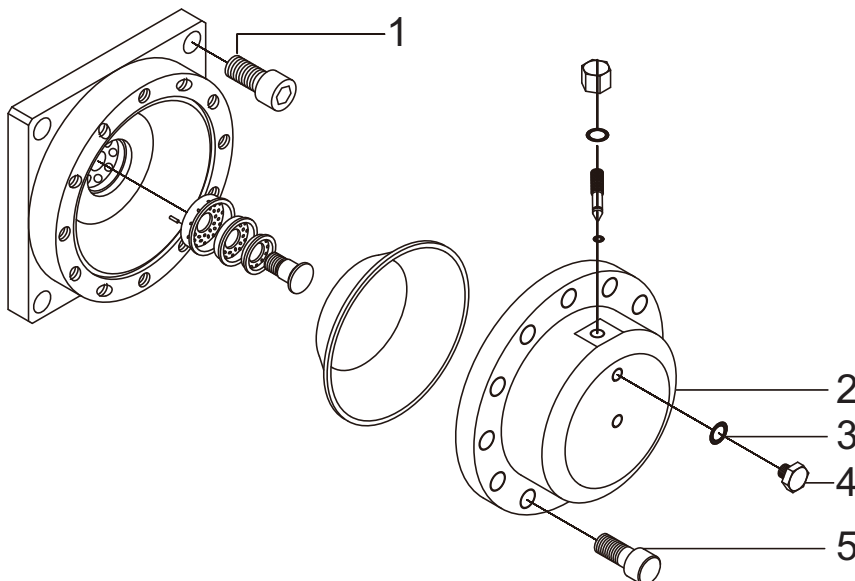

1. Accumulator body bolt
2. Accumulator cover
3. O-Ring
4. Accumulator Hex. Plug
5. Accumulator cover bolt

▲ WARNING!

DO NOT use impact tools to remove the accumulator from the breaker body.

The accumulator mounting bolts use heliserts(steel threaded inserts)that can be damaged by the use of impact tools.

- 1) Take an initial reading of the nitrogen gas pressure in the accumulator. A higher than normal reading may indicate a problem.

▲ WARNING!

A gas pressure reading in the accumulator higher than the last time it was charged indicates the diaphragm may have ruptured.

- 2) Bleed off the nitrogen gas with the charging kit hose. Fully vent the accumulator.
Confirm with the gauge in the charging kit.
- 3) Loosen the 4 bolts in a staggered pattern. Use multiple steps.
- 4) Remove the accumulator from the breaker body.

Diaphragm Replacement

▲ CAUTION

Nitrogen gas must be fully vented before disassembly.

- 1) Confirm the gas pressure has been fully vented with the charging kig hose gauge.
- 2) Loosen the bolts holding the accumulator halves together in a staggered pattern.
- 3) Loosen the bolts off in 1/8 in(3mm) increments; watch for movement.
Movement of the halves may mean residual pressure remains.
- 4) Continue loosening the bolts in a staggered pattern
- 5) Remove the cover to replace the diaphragm.

Accumulator Assembly

- 1) Install the accumulator diaphragm into the accumulator base.
Make sure the groove is clean and free of any debirs
- 2) Lubricate the cover bolt threads
- 3) Install the cover bolts and washers Tighten in stages in a staggered pattern
For information on accumulator bolt torque, see "Torque & Gas pressure table"

Charging the Accumulator

Before the breaker is put into service, the accumulator must be recharged with N₂ gas.

Refer to "Accumulator Gas Pressure - Adjusting"

Control Valve Removal and Disassembly

⚠ CAUTION!

Handle these components with care. Damaging them will cause breaker malfunction.

The control valve is responsible for directing oil within the breaker to move the piston within the cylinder.

The Supplier Model has an internal control valve contained within the cylinder body.

The control valve is housed within the cylinder body. Once the back head is removed, it can be accessed from the upper end of the cylinder body.

- 1) Remove the o-rings, then the valve plug.
- 2) The valve spool and valve sleeve can then be slid out.
If spool is not seized, it can be easily removed.
A puller can assist in removing a seized spool.

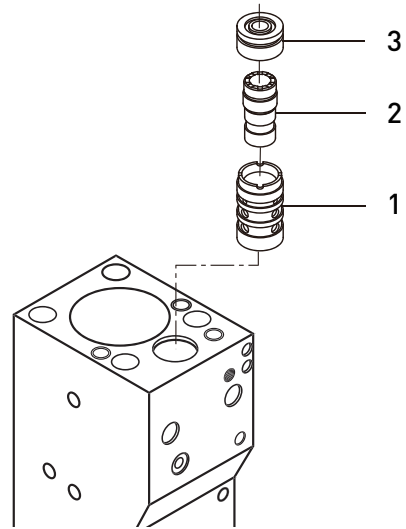

1. Valve Sleeve
2. Valve
3. Valve Plug

Control Valve Inspection

- If the valve spool surface is scuffed, remove it with 800-1200 grit emery cloth. If the area is extremely damaged, replace the valve.
- If the valve body has flaws in area D, smooth the surface with 800-1200 grit emery cloth.
Do not use a buffing grinder on this area.

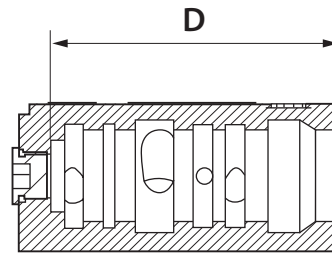

Control Valve Body

- In case of scuffing on the inner diameter G, finish by buffing with a flap wheel.
- Clean all parts of the control valve in clean solvent and dry them with compressed air.

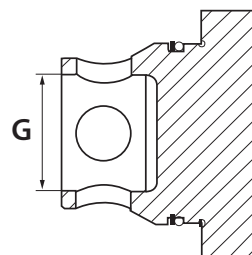

Piston Removal

⚠ CAUTION!

Handle these components with care. Damaging them will cause breaker malfunction.

- 1) Install a lifting eye into the top of the piston.
 - 2) Lift the piston straight up and out of the cylinder.
- NOTE:** Avoid scratching the piston's polished surface. Tapping the cylinder with a soft-faced mallet may ease the removal of the piston. The seal bushing will come out with the piston.
- 3) Place the piston and seal bushing on a clean protective surface.

- 4) The piston should be carefully cleaned and inspected for corrosion, cavitation, pitting, and scoring.
- 5) Check the grooves in the piston for metal that has been pulled-in due to galling. If this has occurred, clean the grooves. Small marks can be removed with an oilstone or fine emery cloth and oil. Check the corresponding mating part as well and treat in the same manner.
- 6) Look for pitting and deformation of the impact face. This indicates that the tool has been operated with too much wear on the tool bushings.
- 7) If the face is dished, carefully measure the amount of deformation.
- 8) Thoroughly clean and dry the piston to protect it from dirt, then set it aside.
- 9) If the piston is not going to be installed immediately, coat it with oil and store it protected in a clean, dry place.

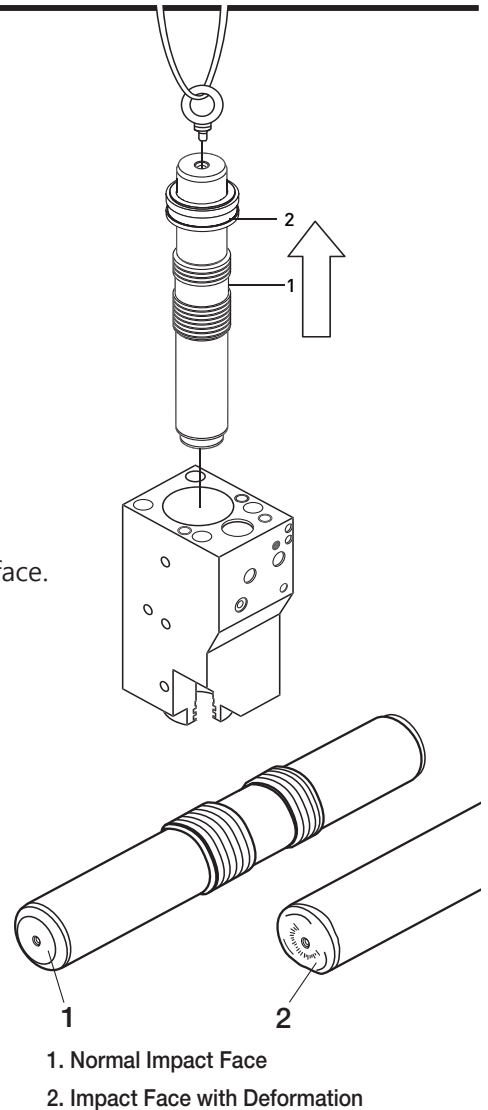

If the piston face is scuffed, finish it with a buffing grinder, then 800-1200 grit emery cloth.

IMPORTANT: When using a buffing grinder, apply the flap wheel around the circumference of the part only. If applied along the axis, roundness of the part will be affected.

Wash the parts after finishing them.

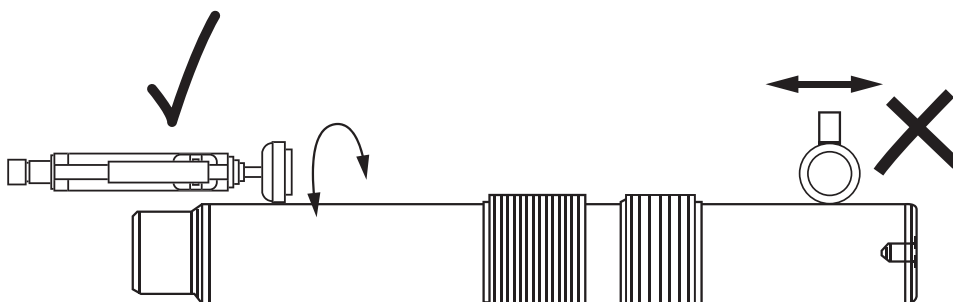

Cylinder Removal

▲ CAUTION!

Handle this component with care. Damage will cause breaker malfunction.

- 1) Install lifting eyes into the top of the cylinder.
- 2) Lift the cylinder straight up off the tie rods.
- 3) Loosen and remove the tie rods.

It may be necessary to secure the front head to prevent it from rotating.

- 4) Loosen the tie rods by rotating them counter-clockwise.

Use an adjustable wrench and a soft faced mallet or a sledge wrench on the tie rod flats to loosen them.

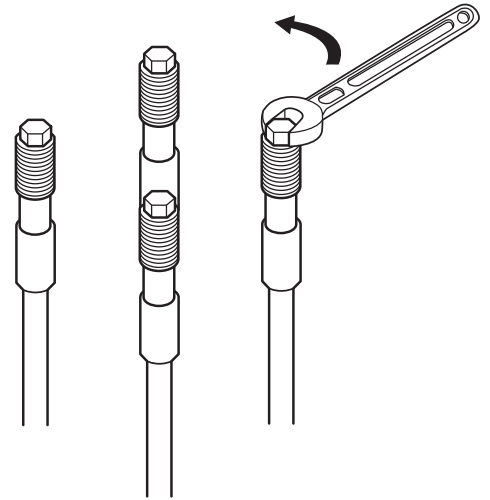

The cylinder should slip out of the front head. If not, tap the front head with a soft-faced mallet until the cylinder and front head come apart.

Cylinder Inspection

- Thoroughly clean the cylinder bore, and remove the dust seal, oil seal, and slide ring. Check the seals for signs of extension and excessive wear both before and after removal.
- Thoroughly inspect inside walls of the cylinder for corrosion, cavitation, or scoring. Check grooves above seal area for small pieces of metal, due to galling. If these are not cleaned out they will chip off and go between the piston and cylinder, and galling will occur again.
- Check for any damage to the heliserts that secure the control valve. Repair or replace as necessary to ensure the valve can be installed properly.
- Inspect the main inlet and outlet adapter threads for damage. Always replace the seals if they are removed.

▲ CAUTION!

Do not install the hydraulic adapters in the wrong port.

The pressure adapter has a smaller through hole than the tank adapter.

The cylinder is marked "IN" beside the pressure adapter and "OUT" beside the tank adapter.

Cylinder clean-up

Any slight galling and other irregularities on the cylinder wall must be removed before reassembly.

Use a cylinder hone to ensure the cylindricity of the bore is maintained.

After using a hone, deburr the edges of all the lands.

The preferred method to remove irregularities is to use a blade (fixed type) hone.

A second method is to use a flexible hone. The amount of deburring required will be reduced with the flexible hone.

A die grinder should only be used for deburring edges and severe local points of galling.

If damage is too great, call your Supplier.

- Check the slide areas A, B and C for flaws.
If there are scuffing flaws, finish the surface smooth with a cylinder hone.
- If there are flaws in area D, use 800-1200 grit emery cloth.
Never use a buffing grinder in this area.
- Area E can be finished by buffing with a grinder.

Wash the parts after finishing them.

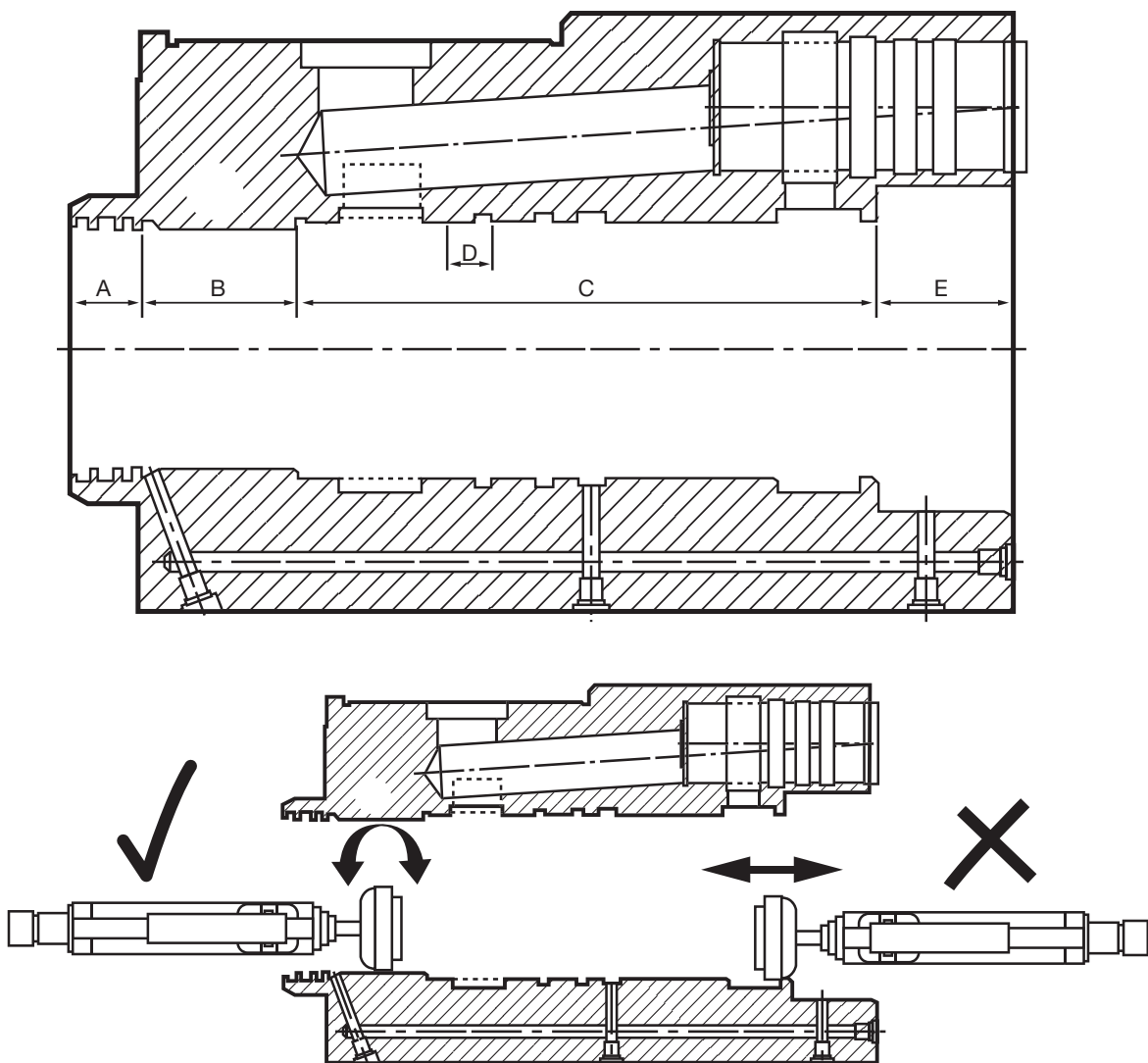

IMPORTANT: When using a buffing grinder, apply flap around the inside diameter of the part only. If applied along the axis, roundness will be affected.

Seal Bushing Inspection

Clean and inspect the cylinder seal bushing.

The seal bushing carries several specially designed seals. Pay attention to the condition and orientation of the old seals as they are removed.

This may help to identify any operating problems that the breaker had before it was dismantled.

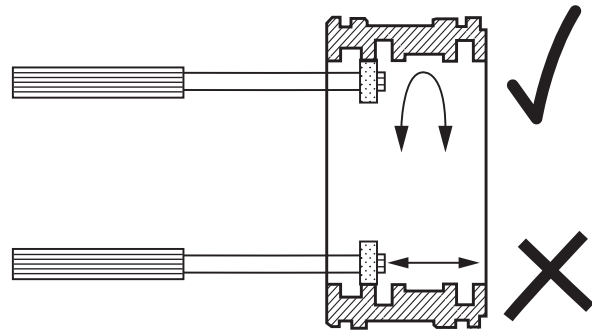

If burrs are found on the seal bushing, use a buffing grindstone to remove them.

IMPORTANT: When using a buffing grinder, apply the flap wheel around the inside diameter of the part only. If applied along the axis, roundness will be affected.

▲ CAUTION!

Handle this component with care. Damage will cause breaker malfunction.

All parts should be thoroughly washed in clean solvent and dried with compressed air.

Once the seal bushing is clean and dry, protect it from dirt and set it aside.

Tie Rod(Through Bolt) Installation

Inspect the tie rod threads. If they are damaged beyond repair, the tie rod must be replaced.

- 1) Lubricate the tie rods and threads thoroughly using grease.
- 2) Install the tie rods and tighten until they bottom out in the front head.
- 3) The tie rods should turn in smoothly and easily until they seat themselves. If they do not bottom out or there is excessive resistance, the threads on the tie rods may be damaged.

NOTE: As a reference, tie rod torque can be found in Torque Specifications

Cylinder Installation

- 1) Check the cylinder for burrs.
- 2) Liberally oil the inside surface of the cylinder and the new seals, then install the seals and rings into the grooves at the lower end of the cylinder.
- 3) Lower the cylinder carefully onto the tie rods.
The control valve mounting holes on the cylinder must face the same direction as the grease fitting on the front head.

- Pay close attention to the correct placement and orientation of the seals. Improper seal installation will cause premature leakage and premature wear.

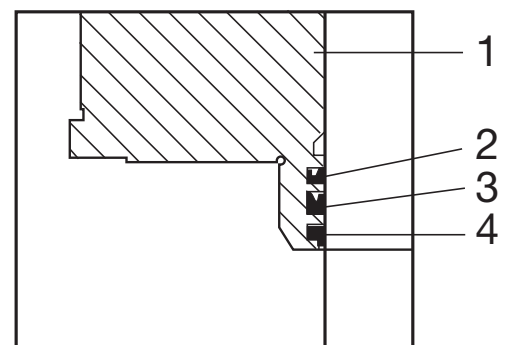

1. Lower Cylinder
2. Buffer Seal
3. U-Packing
4. Dust Seal

Seal Bushing – Re-sealing

Ensure the bushing is clean and there are no burrs.

- Oil the seal bushing and seals.
- Install the seals and o-rings in the correct positions and orientations.

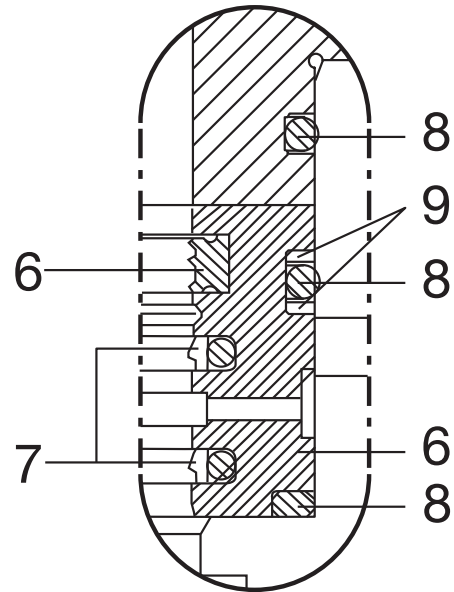

- 6. Gas Seal
- 7. Step Seal
- 8. O-ring
- 9. Back-up ring

Piston Installation

- 1) Lubricate the top end of the piston, and slide the seal bushing into place, with the chamfer or step towards the center of the piston.
- 2) Lift the piston with the lifting eye, lubricate it thoroughly, and lower it carefully into the cylinder. It may need a tap to push it through the lower seals.
- 3) When the piston is all the way into the cylinder bore, use a soft mallet to tap the seal bushing into position in the cylinder. The bushing will stop when it reaches the support flange on the front head.

Replace the o-rings and back-up rings on the top of the cylinder where the rear head makes contact.

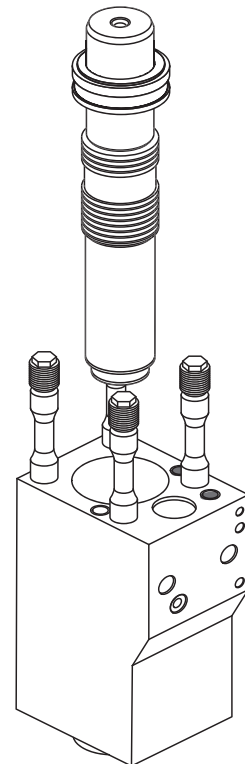

Control Valve Installation

Control valve is housed within the cylinder body.

It is installed from the upper end of the cylinder body.

Lightly oil the control valve spool, valve sleeve, plug and o-rings with clean hydraulic oil.

- 1) Insert the valve sleeve first, then insert the spool.
Insert the small end of the spool first.
- 2) Insert the plug and ensure the o-rings are placed correctly before installing the rear head.

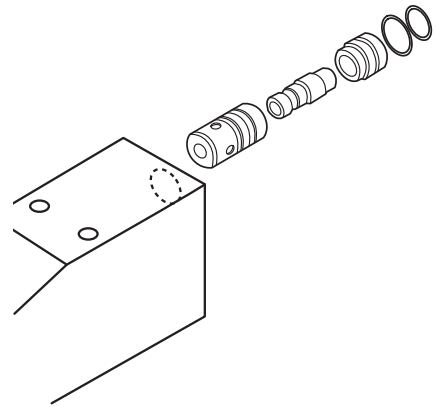

Installing Rear(Back) Head

The cushion chamber in the rear head needs a small amount of oil to function properly. Just before installing the rear head, make a circular dam of grease on the top of the piston, just high enough to contain the required amount of oil (see table below).

- 1) Lower the rear head over the tie rods. The gas valve must face the same direction as the control valve on the cylinder.
- 2) Install the tie rod washers.
- 3) Lubricate the tie rod nuts with grease, and tighten them in a crossing pattern to draw the breaker components together evenly.
- 4) Finish tightening the nuts to the correct torque in four stages – 40%, 60%, 80% and 100% using the same crossing pattern.

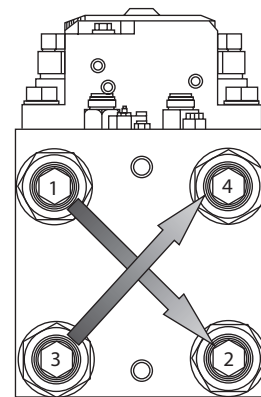
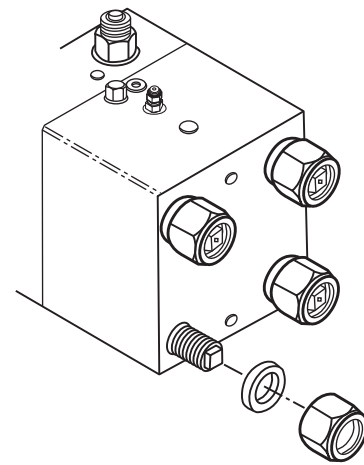

Tie Rod(Through Bolt) Nut Torque

See "Torque and Gas Pressure Table- Page 43"

Charging the Cushion Chamber

Before the breaker is put into service, the cushion chamber must be recharged with N₂ (nitrogen) gas.

Breaker Assembly

(Installing body into boxed frame)

▲ WARNING!

Hydraulic breakers and their components are heavy! Plan carefully how you will handle them when removing, disassembling, or installing the breaker. Stand clear when slinging the breaker off the ground.

The Supplier breaker uses upper and lower isolators to support the breaker body within the housing.

IMPORTANT! After the top mount bracket is installed, the upper and lower isolators must compress to form a spring pre-load on the breaker body within the housing. If the breaker body has been disassembled to be rebuilt, replace the isolators.

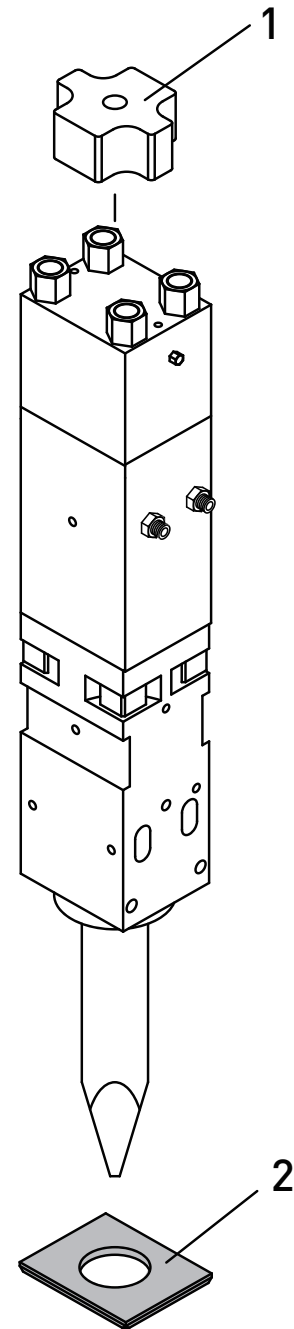

- 1. Cross Damper(Upper Isolator)
- 2. Lower Damper(Lower Isolator)

NOTE: The upper/lower isolators and wear pads are considered wear parts and are not covered under the breaker warranty. It is recommended that they be replaced after every 1000 hours of operation or as required.

⚠ CAUTION!

Check to make sure the housing is upright, secure, and fully restrained.

- 1) Install the wear pads and lower isolator into the breaker housing.

NOTE: Do not lubricate the wear pads to ease installation of the breaker body.

NOTE: If the breaker body is new, check to make sure nothing is protruding to hinder insertion into the housing.

- 2) Lift the breaker body up and center it for entry into the housing.

Check the orientation of the body—the pressure and return ports must face the control valve side.

- 3) Slowly lower the breaker into the housing.

The breaker may have to be slightly tapped in using a dead blow.

If the breaker binds or seizes in the housing, remove it and determine the cause.

- 4) Keep the lower isolator centered – nylon side up.

- 5) Lower the breaker until it fully bottoms out in the housing.

Check by comparing the position of the retaining pins and the clearance holes in the bottom of the housing.

The retaining pins should be just above the centerline of the clearance holes.

- 6) Position the upper isolator on the rear head.

Verify it protrudes above the finished face of the breaker housing.

See previous page.

- 7) Position the mounting bracket on the top of the breaker.

Ensure bracket is not put on backwards, and install bolts.

- 8) Lubricate the bolts with MoS2 grease.

- 9) Tighten bolts in a cross pattern to provide even loading to the upper isolator.

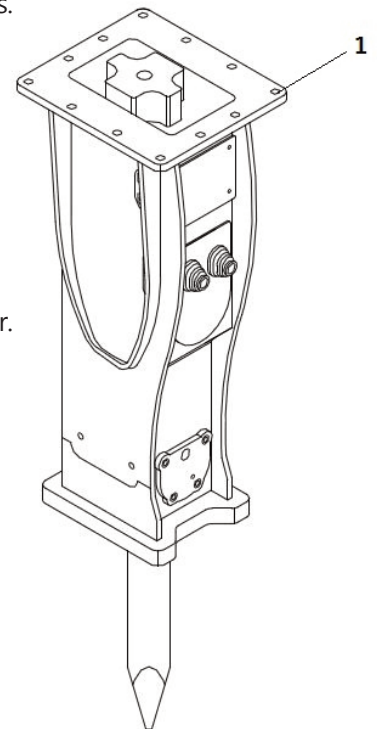
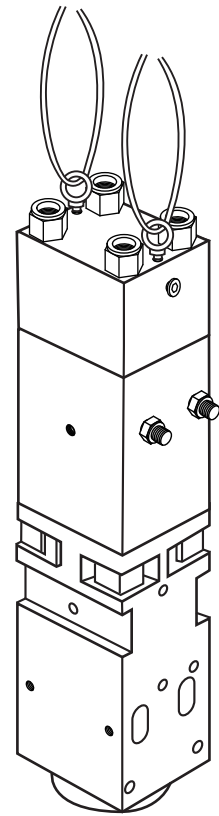

Top Mount Bracket Bolt Torque

See "Torque and Gas Pressure Table" Page 43"

⚠ CAUTION!

Use extreme care to prevent dirt from entering the hydraulic circuit when disconnecting or reconnecting hydraulic lines. Cap or plug lines when disconnecting; clean thoroughly before reconnecting. Even the smallest dirt particles will cause damage to the internal workings of the breaker.

- Install the breaker onto the carrier and reconnect the pressure and return lines.

Start-up

Air may have been introduced to the hydraulic circuit and may cause a malfunction. Warm the carrier hydraulic system up to operating temperature, then cycle the oil to remove the air:

- 1) Lift the unit off the ground.
- 2) Press the start button or pedal to fire the breaker momentarily.
- 3) Continue to turn the breaker ON and OFF in this manner for 10 minutes.
- 4) Work the breaker in soft material in short bursts for 10 minutes.
- 5) Check for any loose bolts or oil leakage.

The breaker is now ready to operate.

High Speed and Low Speed Valve Adjusting (Valve Adjuster).

The manual High/Low Speed Selecting Valve Adjuster is on upper right side on Cylinder

High Speed Stroke Setting,

- 1) Turn the valve adjuster screw (1) 3 complete turns anti-clockwise from normal factory setting.

Low Speed Stroke Setting,

- 1) Turn the valve adjuster screw (1) to bottom out (tight)

***If it is hard to turn valve adjuster because of the valve nut (2) tight, please loosen the valve adjuster nut(2) a little bit to make valve adjuster turn easily.**

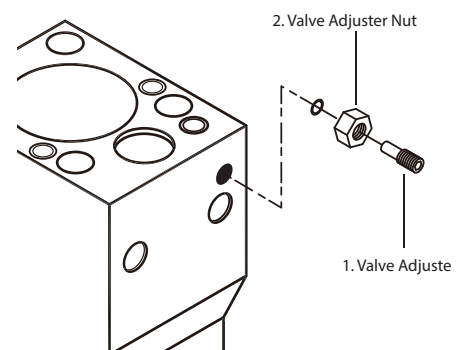
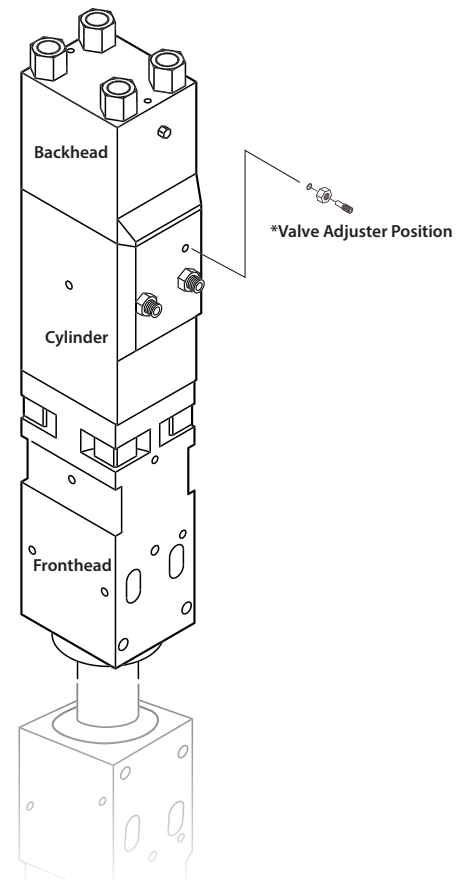
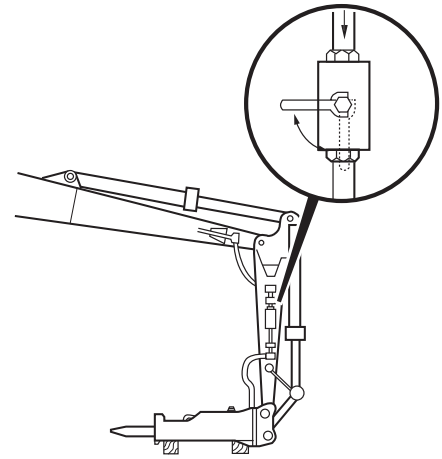

Troubleshooting Guide

Oil Leakage

If oil leakage develops, it may not be necessary to replace parts.

Check the following points in the table below before calling your Supplier.

A slight amount of oil seepage around the breaker connecting parts is normal during the first 200 hours of operation.

Area of Leakage	Area of Leakage	Area of Leakage
A		
The space between the tool and the bushing. Large amounts of oil coming out.	Damaged seals.	Re-seal as necessary.
B		
Oil over the surface of the breaker.	Loose hydraulic hoses or adapters.	Check condition of hydraulic hoses and adapters. Tighten as necessary.
C		
Joining surface of cylinder and rear head. Oil oozing. New oil leaking.	Loose tie rod nut. Damaged o-ring.	Tighten tie rod. Replace damaged o-ring.
D		
Joining surface of cylinder and front head. New oil leaking.	Loose plugs on face of cylinder. Damaged seals.	Tighten loose plugs. Replace damaged seals as necessary.
E		
High/low speed selector. Oil running down breaker.	Loose locknut. Damaged O-ring.	Tighten loose locknut. Replace damaged O-ring.

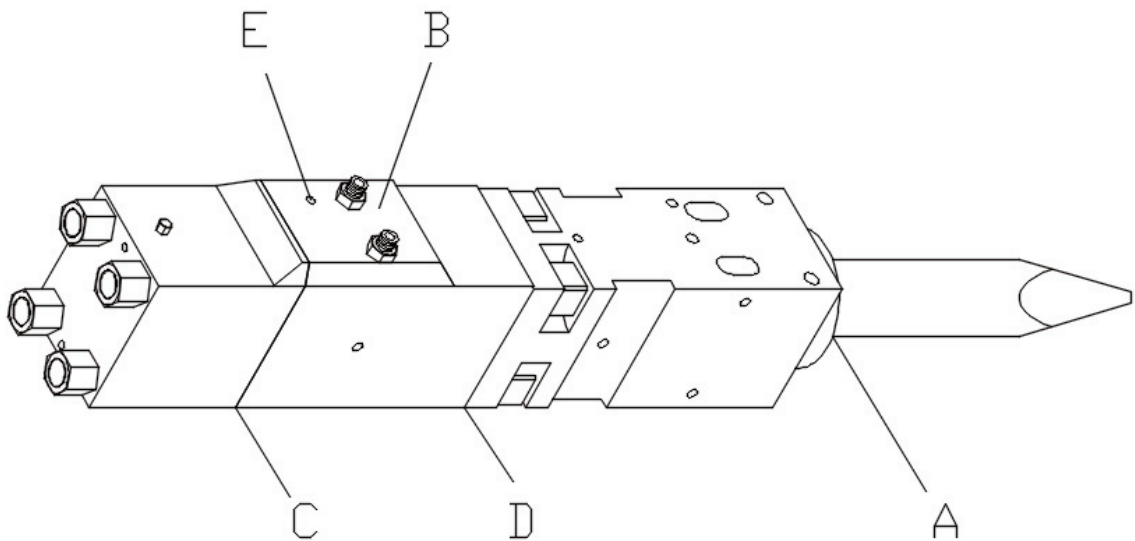

Hydraulic Breaker

Does not hammer

Probable Cause	Correction
Anti-blank fire has activated.	Push breaker down on tool to disengage blank fire mode.
Base carrier selector valve does not operate correctly.	Check connection from cab controls to selector valve.
Poor performance of the hydraulic pump.	Check pump outlet. Repair or replace.
Pressure relief valve set too low.	Check relief settings and adjust.
Clogged or restricted hoses.	Clean or replace.
Cushion chamber filled with oil.	Replace seals.
Seizure of breaker.	Overhaul and replace worn parts.
Back-pressure too high in circuit.	Find source causing increased back-pressure in return circuit and remove.
Control valve bolts loose.	Tighten bolts to correct torque in a staggered pattern.
Check all ball valves.	Open ball valve.

Does Not Impact

Probable Cause	Correction
Temperature of the hydraulic oil is too low.	Warm up the hydraulic excavator.
The nitrogen gas pressure in the cushion chamber is too high.	Adjust the nitrogen gas to the correct pressure.
Pressure setting for the relief valve is too low.	Set the relief valve to the correct pressure setting.
Poor performance of the hydraulic pump on the excavator.	Have the hydraulic excavator manufacturer check the pump performance. If the performance is poor, repair or replace.
Back-pressure too high in circuit.	Find source causing increased back-pressure in return circuit and remove.

Lack of Power

Probable Cause	Correction
Insufficient oil flow or oil pressure.	Check hydraulics of the base carrier.
Broken tool.	Replace tool, check piston for damage.
Cushion chamber gas pressure is too low.	Check and adjust.
Back-pressure too high in circuit.	Find source causing increased back-pressure in return circuit and remove.

Erratic hammering

Probable Cause	Correction
Hydraulic oil temperature is too high.	Oil temperature must not exceed 158°F(70°C).
Insufficient oil flow and/or pressure.	Check base carrier hydraulic system.
Clogged or restricted hoses, or pipes.	Clean or replace.
Not enough down force on the tool.	Increase the down pressure acting on the tool.
Pressure too high in cushion chamber.	Adjust pressure.
Too much grease in the impact chamber.	Remove tool and clean out excess grease. Follow proper greasing instructions.
Excessive clearance between tool and tool bushing.	Check clearance and replace worn parts.
Excess wear at top of tool.	Remove and inspect the tool. Replace if necessary.
Foreign matter in the breaker control valve.	Disassemble and clean.
Seizure of piston and cylinder.	Overhaul the breaker.
Back-pressure too high in circuit.	Find source causing increased back-pressure in return circuit and remove.
Control valve bolts loose	Tighten bolts to correct torque in a staggered pattern.

Tool Mushrooming

Probable Cause	Correction
Continuous hammering in one place.	Use short bursts. Re-position breaker every 20 seconds.

Rapid Increase in Oil Temperature

Probable Cause	Correction
Insufficient oil cooling.	Check oil cooler.
Insufficient oil flow.	Check pump output.
Incorrect oil pressure.	Check relief valve setting.

Emulsification of Oil

Probable Cause	Correction
Oil contaminated with water.	Locate source of water and repair. Replace oil.

Leakage

Probable Cause	Correction
The space between the tool and bushing has large amounts of oil coming out.	Damaged seals. Re-seal as necessary.
Possible loose hoses or adapter fittings cause oil over the surface of the breaker.	Check condition of hoses and fittings, tighten as necessary.
Oil oozing after overhaul of breaker, between the control valve and surface of the cylinder.	Normal oozing of assembly lubricants.
Oil ooze after overhaul of breaker, between the joining surfaces of cylinder and rear head.	Loosen tie rod nuts, and retighten. Damaged o-ring, replace.
New oil leaking from surface between cylinder and front head.	Loosen plugs on face of the cylinder, then re-tighten. Damaged seals in the cylinder, replace as necessary.
Between the cylinder and hose adapter.	Replace worn or damaged o-ring. Check and re-tighten the hose adapter to the specified torque.
Leakage at stroke adjuster cap.	Replace worn or damaged o-ring. Loosen the stroke adjuster cap, then re-tighten to specified torque.
Leakage at pilot valve cap.	Replace worn or damaged o-ring. Loosen the pilot valve cap, then re-tighten to specified torque.
Control valve bolts loose	Tighten bolts to correct torque in a staggered pattern.

Gas Leakage

Probable Cause	Correction
Gas leakage from the gas valve.	Replace worn or damaged seals. Check gas valve for damage repair or replace.
Leakage from gas valve body.	Worn or damaged o-ring. Replace.
Gas leakage from between the cylinder and the cylinder cover.	Worn or damaged o-ring. Replace.
Tie rods loose.	Tighten to correct torque value in a cross pattern.

Erratic Blows After Breaker has been Operating Normally

Probable Cause	Correction
Seizure of control valve.	Repair or replace control valve.
Seizure of piston and cylinder.	Remove and inspect piston, and inside of cylinder body.
Relief valve for the excavator is set too low.	Set the relief valve to correct pressure setting.
Poor performance of the hydraulic pump on the excavator.	Have the hydraulic excavator manufacturer check the pump performance. If the performance is poor, repair or replace.
Lack of down pressure on the tool.	Operate the arm and bucket so that pressure is applied to the tool.
Nitrogen gas pressure in the rear head is too low.	Adjust the nitrogen gas to the correct pressure.
Back-pressure too high in circuit.	Find source causing increased back-pressure in return circuit and remove.
Control valve bolts loose	Tighten bolts to correct torque in a staggered pattern.

Blows/min decreased

Probable Cause	Correction
Nitrogen gas pressure in the rear head is too high.	Adjust the nitrogen gas to the correct pressure.
Lack of down pressure on the tool.	Operate the boom and bucket cylinders so that pressure is applied to the tool.
Pressure setting for the relief valve is too low.	Set the relief valve to the correct pressure setting.
Poor performance of the hydraulic pump on the excavator.	Have the excavator manufacturer check the pump performance.
Clogged or restricted hoses, pipes.	Investigate the blocked area and repair or replace.
Back-pressure too high in circuit.	Find source causing increased back-pressure in return circuit and remove.

Tool Breaking

Probable Cause	Correction
Abuse of tool and prying with tool.	Apply down force in the direction of tool only. Check for excess play in arms, links, and pins.

Breaker Tool

Normal Breaker Tool Wear

Wear depends on rock conditions. Hard, abrasive rock wears the tool down faster. Working in softer materials will keep the point shape longer.

Blunt tools (A) will wear back 1/3 of the diameter to be shaped as shown.

Moil and Chisel tools (B & C) will wear back 2 inches (51mm) or more to be shaped as shown.

As a general guide, this is considered normal wear and reasonable tool life.

Warranty claims are not accepted for normal wear.

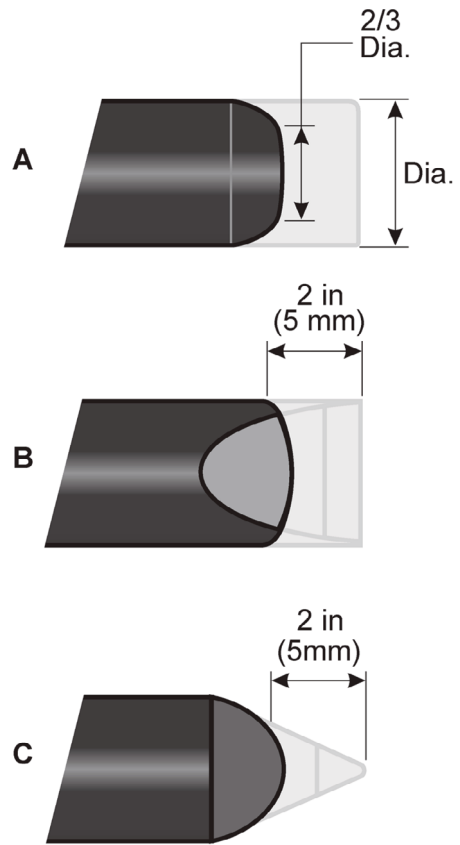

10288

Breaker Tool Fatigue Failures

Metal Fatigue

Metal fatigue is the sudden fracture of a component. This effect occurs on metal after a period of repeated cycles of stress. Normally, there will be no obvious warning. A crack forms without any visual change making it difficult to detect the presence of growing cracks. Fractures usually start from small nicks or scratches or fillets that cause a localized concentration of stress.

The fracture face itself normally appears as a semi-circular polished area with the remainder looking uneven and rough.

The polished semi-circle is the fatigue area, originating from a damage mark or other stress event outside of the tool.

The fatigue area spreads slowly into the tool, until the stress causes sudden failure to the section. Generally, the size of the fatigue area indicates the level of stress applied to the tool, i.e. the smaller the fatigue area, the higher the stress level.

Once a fatigue crack begins, it takes less stress to make it grow.

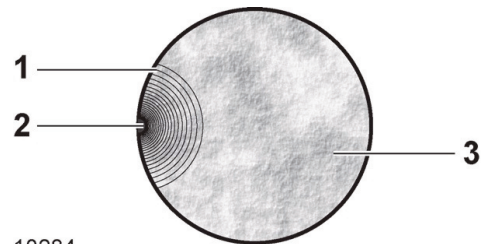

10284

Cause and Effect of Fatigue

In normal operation, a cycle of compressive and tensile stresses flow up and down the tool with each piston blow as the breaker fires. The main cause of increased tool fatigue stress is any side force applied during operation that bends the tool. Prying with the tool, using the incorrect working angle, or attempting to break ground using the pull of the carrier machine will shorten tool life and must be avoided.

Anything that interferes with these normal stresses increases the risk of early tool fatigue failure.

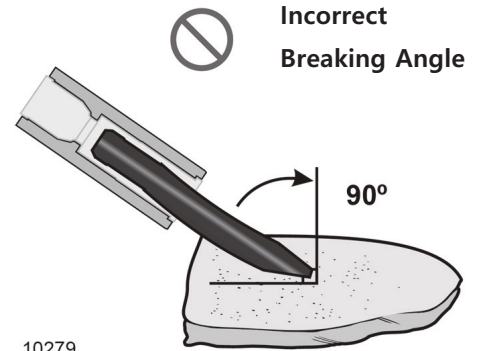

Other Causes of Increased Tool fatigue Stress

Blank Firing

Blank firing is any situation where the breaker piston strikes the top of the tool, but the tool is not in proper contact with the material. This can happen when the tool slides off the work and also when breaking through thin concrete slabs or boulders.

Cold

Low temperature makes the tool more susceptible to fatigue failure. Warm the tool first with moderate or light breaking.

Mechanical and Thermal Damage

Any type of damage to the tool surface makes it more likely to suffer fatigue failure.

Care must be taken to:

- Prevent scratches, gouges, weld marks.
- Keep tool well lubricated.
- Operate properly and avoid excessive bending of the tool.

Poor Lubrication

Metal to metal contact causes material pick up that can scrape deep damage marks. These will develop into fatigue cracks, causing tool failure.

Ensure the tool shank is well lubricated before inserting into the tool holder. Molybdenum disulfide grease or Supplier's own brand of Chisel Paste (containing copper, graphite and silica) is recommended at 2 hour intervals.

- Make sure tool is pushed up fully inside the breaker.
- Grease until clean grease runs freely from cavities.

Prying with Breaker

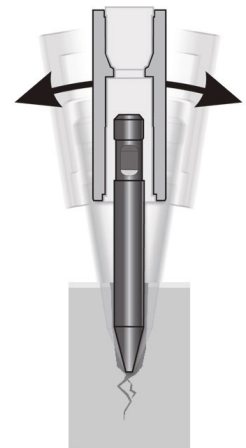

Pulling with Carrier

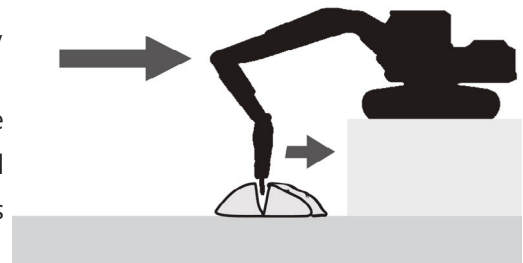

Corrosion

Keep spare tools well greased and sheltered from the weather when not in use. A rusty tool is more prone to fatigue failure.

Area of Typical Tool Failures

Guide to Warranty Claims

Supplier tools are manufactured from top quality materials and heat-treated to produce a fatigue and wear resistant tool.

When a tool fails to give satisfactory service life, a brief visual inspection usually reveals the cause.

- A tool metal "fatigue" failure generally occurs within 4 in (100 mm) above and below the face of the front head, or at the retainer pin flat.
- A less common failure area is about 8 in (200 mm) from the face of the front end, depending on the work the breaker is doing.

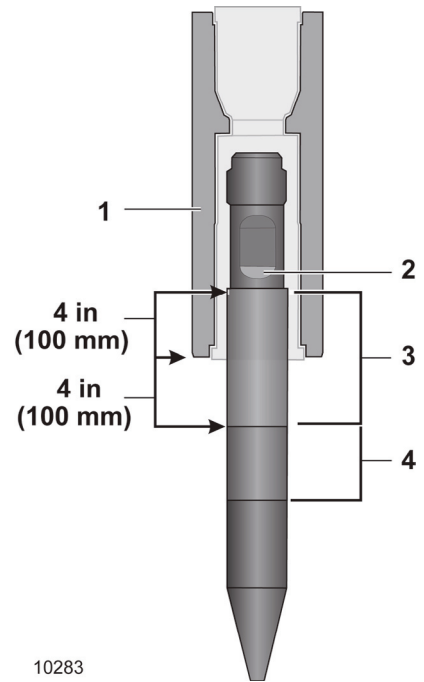

10283

1. Front Head
2. Retainer Pin Flat
3. High Risk Fatigue Area
4. Low Risk Fatigue Area

Typical fractures caused by excessive bending of the tool.

Fractures like this are not covered by warranty.



10282

Typical fracture caused by prying with the tool while it was buried in the work piece.

Fractures like this are not covered by warranty.



10287

Mushrooming

Hammering the tool too long in hard dense material without penetrating through causes mushrooming. This generates intense heat that softens and mushrooms the point. This is not a fault of the tool. If the rock or stone shows no sign of breaking within 20 seconds, reposition the breaker.

Warranty claims made for mushrooming on the ends of the tool will be rejected.

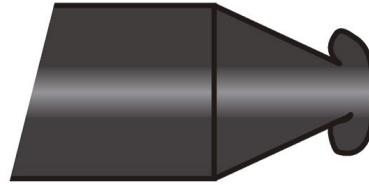

10289

Steel Defect Failure

This failure has fatigue lines originating from an internal point, and not from the outer surface. This is a very rare failure caused by a defect in the steel.

This type of defect is covered under the normal warranty period.

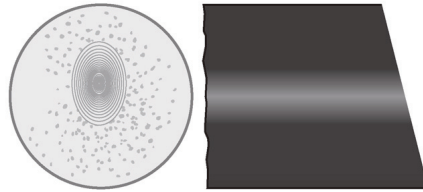

10290

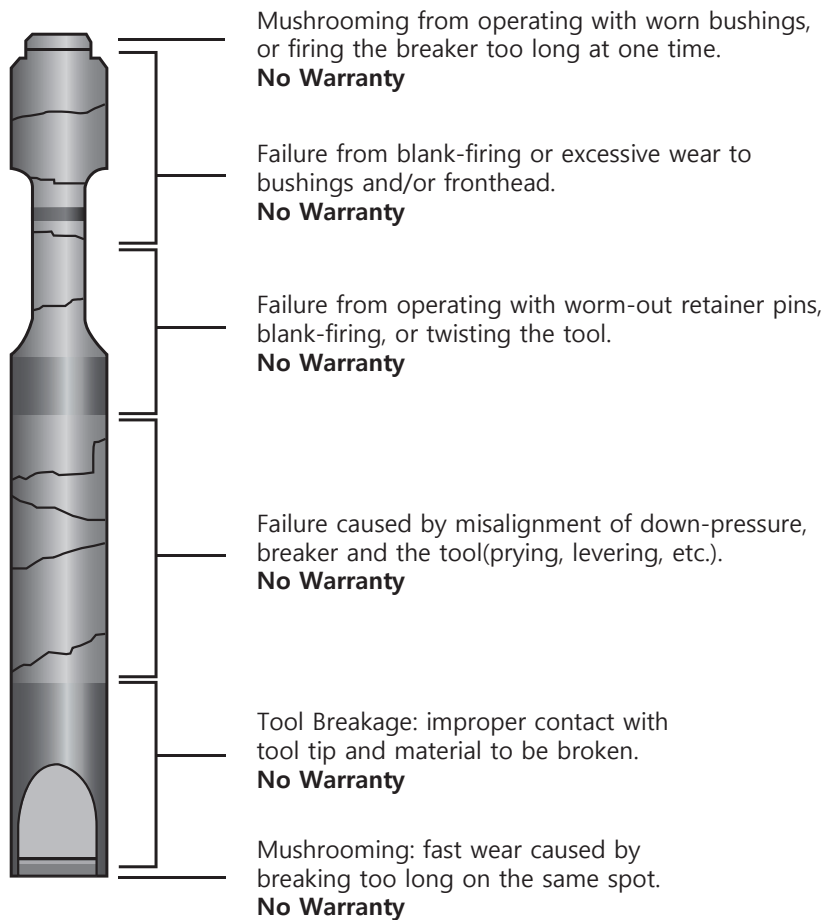

Removal and Storage

▲ CAUTION!

Use extreme care to prevent dirt from entering the hydraulic circuit when disconnecting or reconnecting hydraulic lines. Cap or plug lines when disconnecting; clean thoroughly before reconnecting. Even the smallest dirt particles will cause damage to the internal workings of the breaker.

Short-term Storage

Storing your breaker up to a week is considered Short-term Storage.

Follow this procedure:

- 1) If shut-off valves are used with the breaker, turn them to the OFF position.
- 2) Disconnect the pressure and return lines. Plug the lines and the breaker ports to prevent contamination.
- 3) Use your excavator to lay the breaker on wooden blocks with the mounting bracket end lying higher than the tool end. Support the breaker before proceeding.
- 4) Remove the pins to disconnect the breaker from the carrier.
- 5) Remove the tool and ensure the retaining pins, bushings and piston bottom (inside breaker) are well greased.
- 6) Reinstall the tool and cover the breaker with a tarp. Use a waterproof cover if storing outdoors

Long-term Storage

Storing the breaker over a week is considered Long-term Storage.

Breaker Stored Lying Down

Use the following procedure:

- 1) Release the cushion chamber gas pressure.
- 2) Remove the tool and liberally grease the piston bottom, retaining pins and inside the front head.
- 3) Ensure inlet ports are open to allow piston to move up to the top.
- 4) Push the piston up inside the breaker and reinstall the tool.
- 5) Lay the breaker on wooden blocks (using your excavator). Mounting bracket end should lie higher than the tool end.
- 6) Cover the breaker with a tarp (waterproof if outdoors).

Breaker Stored Standing Up

If the breaker is to be stored standing up, place in a safety stand. Use the following procedure:

- 1) Release the cushion chamber gas pressure.
- 2) Remove the tool and liberally grease the piston bottom, retaining pins and inside the front head.
- 3) Ensure inlet ports are open to allow piston to move up to top
- 4) Reinstall the tool and place the breaker in the vertical stand. This will allow the breaker's weight to push the tool and piston up inside the breaker.
- 5) Cover the breaker with a tarp (waterproof if outdoors).

Initial Start-up after Storage

▲ CAUTION!

Use extreme care to prevent dirt from entering the hydraulic circuit when disconnecting or reconnecting hydraulic lines. Cap or plug lines when disconnecting; clean thoroughly before reconnecting.

Even the smallest dirt particles will cause damage to the internal workings of the breaker.

Storage can introduce air into the hydraulic circuit. If air is present in the hydraulic circuit during operation, it may cause a malfunction.

Circulating the oil will remove air and other foreign substances from the system. If the breaker was stored lying down, seals can deform. Follow these steps to circulate the hydraulic oil, and correct these problems:

- 1) First, recharge cushion chamber with nitrogen gas.

With the breaker mounted and oil warmed to operating temperatures:

- 2) Lift the unit off the ground.
- 3) Press the Start button or pedal to fire the breaker momentarily.
- 4) Continue to turn the breaker ON and OFF in this manner for ten minutes.

The breaker is now ready to be put into service.

RBI HYDRAULIC BREAKER INSTALLATION CARD

Date:

THIS CARD MUST BE FILLED IN AND RETURNED IN CASE OF CLAIM REPORT FOR CARRYING OUT OF THE CLAIM SERVICE DURING THE WARRANTY PERIOD.

1. BREAKER MODEL:
2. SERIAL NO:
3. EXCAVATOR MODEL:
4. INSTALLATION DATE:

■ DISTRIBUTOR INFORMATION:

COMPANY NAME	
PERSON IN CHARGE	
E-MAIL	
TEL:	

■ CUSTOMER INFORMATION:

COMPANY NAME	
PERSON IN CHARGE	
E-MAIL	
TEL:	

WARRANTY CLAIM FORM

Date:

■ **DISTRIBUTOR INFORMATION:**

COMPANY NAME	
PERSON IN CHARGE	
E-MAIL	
TEL:	

■ **CUSTOMER INFORMATION:**

COMPANY NAME	
PERSON IN CHARGE	
E-MAIL	
TEL:	

■ **BREAKER INFORMATION:**

BREAKER MODEL	
SERIAL NO	
EXCAVATOR MODEL	
INSTALLATION DATE	

DESCRIPTION OF PROBLEM OR DEFECT

--

Note : Defected Photos and relevant video will be submitted, if required.

WARRANTY PERIOD OF SUPPLIER

Warranty Period:

12 months from the date the product are delivered to the end users or
18 months from the date of Shipment, whichever comes first.

Part Name	Warranty Period	Remarks
Cylinder, Piston	12 months	
Valve Assembly	12 months	
Front & Back Head	6 months	
Tie Rod(Through Bolt), Side bolt	6 months	
Seal, Diaphragm	6 months	
Bracket(Housing)	6 months	
Welding parts	6 months	
Front Cover, Ring Bush	3 months	
Tool(Rod) pins, Stop pins	3 months	
Damper, Wear Plates	3 months	
Hydraulic Hoses	3 months	
Tools (Chisels)		
Rest of parts	3 months	